

CSNV700 SERIES

006009
Issue 1

Flux Gate Current Sensors

DESCRIPTION

The CSNV700 Series are advanced flux gate current sensors that use Honeywell's patented technology to bring the best combination of performance and reliability. They are non-intrusive and electrically isolated from the monitored circuit. This ensures a simple and reliable structure without loss of power to the monitored circuit. The CSNV700 Series are rated for a primary current measurement range of ± 700 A dc. They are calibrated and temperature compensated for improved accuracy using multi-point temperature characterization. The CSNV700 incorporates AEC-Q100 qualified integrated circuits to meet higher quality and reliability requirements.

DIAGNOSTIC FUNCTIONALITY/ CAN OUTPUT

The CAN output of the CSNV700 Series provides fault detection and communication capability. Also, the digital CAN communication is resistant to electrical interference. Examples of sensor and host system faults are as follows:

- Sensor fault
- Supply voltage over range
- Supply voltage under range
- Current over range

CUSTOMIZATION

The CSNV700 Series may be customized to meet application needs. Solutions may be tailored to exact specifications for improved time to market, lower total system costs and enhanced reliability. For technical assistance, we provide global engineering and service support for your needs.

DIFFERENTIATION

- **Accuracy:** Multi-point temperature characterization and calibration for improved accuracy over temperature range.
- **Magnetic immunity:** Flux gate configuration and optimized magnetic circuit allow for excellent performance in diverse magnetic environments.
- **Flexible:** Customizable on-board firmware to meet specific application requirements.

VALUE TO CUSTOMERS

- **Accurate:** Designed to enable precise battery state measurement for improved user experience.
- **Ease of use:** Magnetic immunity allows for easy integration into different magnetic environments.
- **Easy system integration:** CAN communication is transmitted using international road vehicle standard ISO 11898. CAN 2.0B is the default protocol, CAN 2.0A is available as a custom variant.

APPLICATIONS

- Current measurement for battery management systems in electrified vehicles (EV, HEV, PHEV or BEV)
- Current leakage detection and fault isolation in charging systems
- Current measurement in energy storage systems
- Fault detection in heavy industrial equipment



AEC-Q100

FEATURES

- Active flux gate current sensing
- Utilizes proprietary Honeywell technology for temperature compensation
- High accuracy and low temperature drift
- Operating temperature of -40°C to 85°C [-40°F to 185°F]
- Digital output: CAN bus output with configurable ID
- Internal diagnostic function
- Different configuration options: Mounting type, baud rate, CAN ID
- UL, CE, UKCA certifications; REACH and RoHS compliant
- AEC-Q100 qualified integrated circuits for higher reliability



PORTFOLIO

Honeywell offers a variety of current sensors for potential use in many applications. To view the entire product portfolio, [click here](#).

Honeywell

FLUX GATE CURRENT SENSORS

CSNV700 SERIES

TABLE 1. ABSOLUTE MAXIMUM RATINGS: SUPPLY VOLTAGE = 12 V

Characteristic	Symbol	Unit	Parameter	Condition
Load dump over voltage	V_S	V	32	400 mSec
Over voltage	V_S	V	24 20	10 min continuous
Reverse polarity	V_S	V	-24	10 min
Supply voltage: minimum	V_S	V	7	Continuous
maximum	V_S	V	18	Continuous
CAN operation: supply voltage under range alarm, no measurement	—	V	7 to 8	CAN continuous
supply voltage over range alarm, no measurement	—	V	18 to 24	CAN continuous
Insulation resistance	IR	MOhm	>500	500 V dc at 1 min
Creepage distance	D_{CP}	mm	10	Hole for busbar
Clearance	D_{CL}	mm	9,5	Hole for busbar
RMS voltage: ac isolation voltage	—	kV	5	50 Hz, 1 min
dc isolation voltage	—	kV	5	1 min

TABLE 2. OPERATING CHARACTERISTICS IN NOMINAL RANGE (I_{PN}): SUPPLY VOLTAGE = 12 V

Characteristic	Symbol	Unit	Specification			Condition
			Min.	Typ.	Max.	
Primary current, nominal measuring range (dc)	I_{PN}	A	-700	—	700	—
Supply voltage	V_S	V	8	12	18	—
Supply voltage hysteresis: maximum	V_{UP}	V	—	18.1	—	When V_S increases
minimum	V_{UP}	V	—	17.7	—	When V_S decreases
	V_{LOW}	V	—	8.1	—	When V_S increases
	V_{LOW}	V	—	7.8	—	When V_S decreases
Current consumption: at $I_p = 0$ A	I_C	mA	—	45	—	$V_S = 12$ V, $T = 25^\circ$ C
at $I_p = 500$ A	I_C	mA	—	180	—	$V_S = 12$ V, $T = 25^\circ$ C
Ambient operating temperature	T_a	$^\circ$ C	-40	—	85	Temperature range with accuracy guaranteed
Total accuracy at 20 A < I_p < 700 A	X_G	%	-0.5	—	0.5	$T = -40^\circ$ C to 85° C, ± 3 sigma, 9 V < V_S < 16 V
Error: at $I_p = 0$ A (offset current)	I_{OS}	A	-0.05	—	0.05	$T = -40^\circ$ C to 85° C, ± 3 sigma 9 V < V_S < 16 V
at $I_p \leq 20$ A	X_G	A	-0.1	—	0.1	$T = -40^\circ$ C to 85° C, ± 3 sigma 9 V < V_S < 16 V
Linearity	ϵ_L	%	—	0.1	—	Room temperature

FLUX GATE CURRENT SENSORS CSNV700 SERIES

TABLE 3. MECHANICAL CHARACTERISTICS

Catalog Listing	Description
Housing material	Plastic PA66-GF25 (UL 94V-0)
Mounting screw	M6, 3 N m maximum torque
Mating electrical connector	TEM PN 1473672-1

Figure 1. Error vs. Current

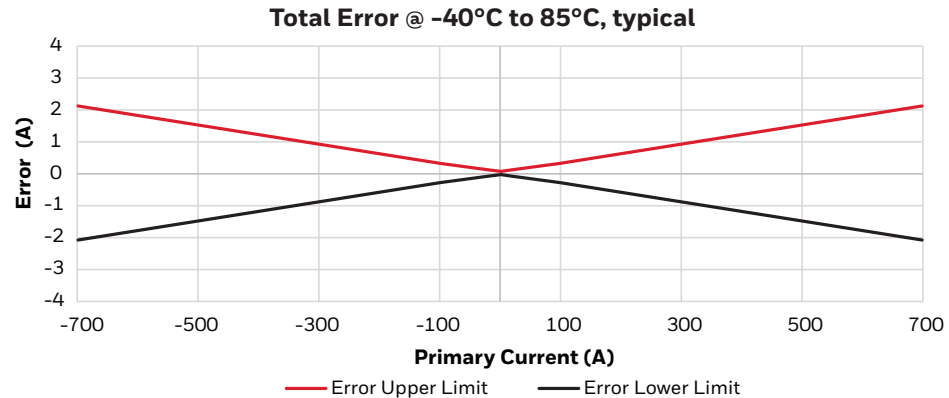

TABLE 4. CANBUS CHARACTERISTICS^{1,2,3,4}

Message Description	Can ID	Data Length	Message Launch Type	Signal Description	Signal Name	Start Bit	Length
Primary current I_p (mA)	0x3C2	8 bytes	Cyclic transmitted message 10 mSec cycle.	I _p value: 80000000h = 0 mA 7FFFFFFFh = -1 mA 80000001h = 1 mA	IP_VALUE	24	32
				Error information	ERROR_INFORMATION	32	7
				Error indication (1 bit): 0 = normal 1 = failure	ERROR_INDICATION	39	1
				Fixed to 0	VACANT_DATA_2BYTES	48	16
				CRC-8 POLY: 8 + X ² + X + 1	CRC_8	56	8

¹CANBUS speed: Refer to Figure 2.

²CAN bus protocol: Version 2.0A/B.

³CAN oscillator tolerance: 0.3125 %.

⁴Byte order: Big endian (Motorola).

TABLE 5. DIAGNOSTIC TROUBLE CODES

Failure mode	I _p Value	Error Indication	Error Information
Flash CRC error	FFFF FFFFh	1	0x48
AFE over range happens¹	FFFF FFFFh	1	0x49
AFE error happens	FFFF FFFFh	1	0x50
Internal LUT error	FFFF FFFFh	1	0x51
Power minimum limit	FFFF FFFFh	1	0x54
Power maximum limit	FFFF FFFFh	1	0x55

¹Overcurrent detection I_p > 740 A.

FLUX GATE CURRENT SENSORS CSNV700 SERIES

TABLE 6. ORDER GUIDE

Catalog Listing	Description
CSNV700N-354	CSNV700 Series flux gate current sensors, 700 rated current, through-hole with metal bushing, 12 V supply voltage, 500 k baud rate, 3C4 CAN ID
CSNV700N-355	CSNV700 Series flux gate current sensors, 700 rated current, through-hole with metal bushing, 12 V supply voltage, 500 k baud rate, 3C5 CAN ID
CSNV700N-356	CSNV700 Series flux gate current sensors, 700 rated current, through-hole with metal bushing, 12 V supply voltage, 500 k baud rate, 3C6 CAN ID

Figure 2. Nomenclature

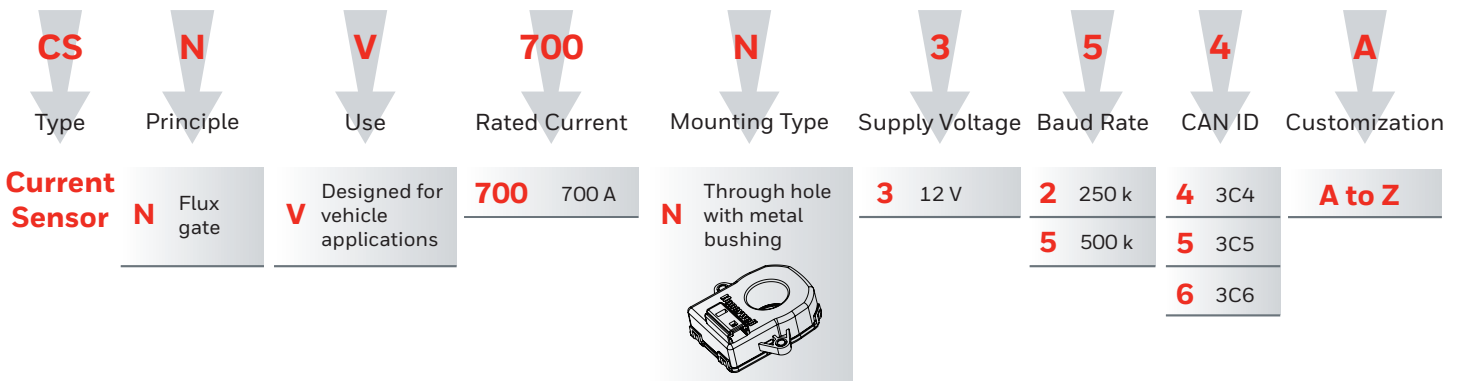
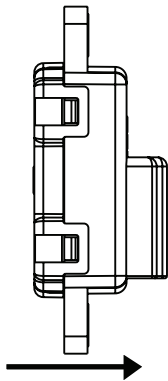

Figure 3. Positive Primary Current Direction (Polarity)

Application condition: Pollution degree PD2



FLUX GATE CURRENT SENSORS CSNV700 SERIES

Figure 4. Dimensional Drawings (For reference only: mm/[in])

Mounting type N: Through-hole with metal bushing

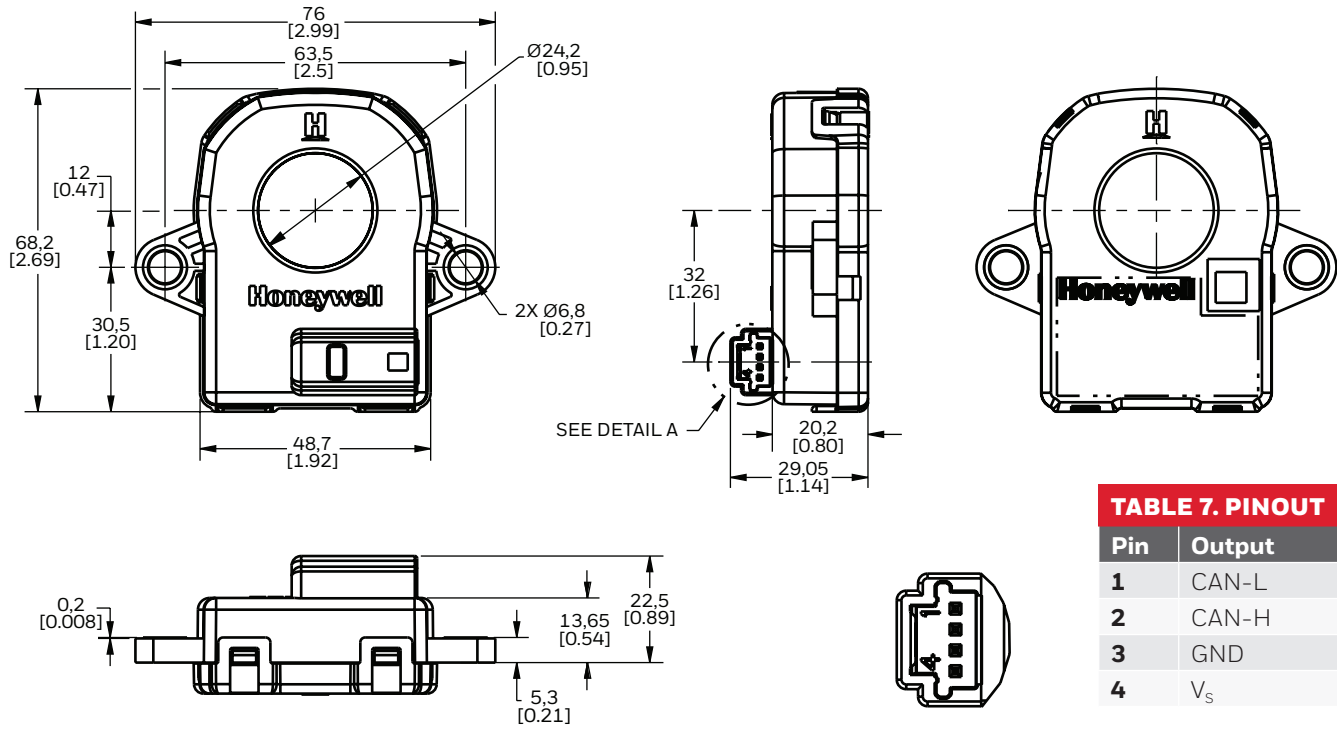

TABLE 7. PINOUT	
Pin	Output
1	CAN-L
2	CAN-H
3	GND
4	V _S

FLUX GATE CURRENT SENSORS CSNV700 SERIES

TABLE 8. EMC TEST SPECIFICATIONS

Test	Standard	Procedure
CISPR 25 conducted RF emissions - voltage on supply lines	CISPR25	According to CISPR 25:2008 commission form of testing
CISPR 25 conducted RF emissions - voltage on supply lines	CISPR25	According to CISPR 25:2008 commission form of testing
CISPR 25 radiated emissions	CISPR25	According to CISPR 25:2008 commission form of testing
Bulk current injection (BCI) test	ISO 11452-4	According to ISO 11452-4
ALSE with a ground plane	ISO 11452-2	According to ISO 11452-2
Transient disturbances conducted along supply lines	ISO 7637-2	According to ISO 7637-2
Transient disturbances conducted along I/O or sensor lines	ISO 7637-3	According to ISO 7637-3
Immunity to magnetic field	ISO 11452-8	According to ISO 11452-8
Handling test	—	See "Electrostatic discharge"
Operating test	—	See "Electrostatic discharge"
Electrostatic discharge	ISO 10605	Unpowered direct contact discharge: ±4 kV, ±8 kV Unpowered air discharge: ±8 kV, ±15 kV Powered-up direct contact discharge: ±4 kV Powered-up air discharge: ±8 kV
Impulse noise test	—	—
Fast transient noise test	—	2 kV power port, 1 kV CAN signal and control port
Radio frequency electromagnetic field	IEC 61000-4-3	10 V/m (80 MHz to 1 GHz), 3 V/m (1.4 GHz to 2 GHz), 1 V/m (2.0 GHz to 2.7 GHz)
Fast transients bursts susceptibility test	IEC 61000-4-4	2 kV power port, 1 kV CAN signal and control port
Radio frequency continuous conducted	IEC 61000-4-6	0.15 MHz to 80 MHz, 3 V 80 % AM (1 kHz)
Radio frequency magnetic field	IEC 61000-4-8	30 A/M
Radiated disturbance (3M semi-anechoic chamber)	CISPR-11	Group 1, Class A

FLUX GATE CURRENT SENSORS

CSNV700 SERIES

TABLE 9. ENVIRONMENTAL TEST SPECIFICATIONS

Test	Standard	Procedure
Shipping/storage temperature exposure	—	Not tested. Covered by low and high temperature operating test.
Low temperature operating endurance	ISO16750-4	120 hr at -40°C, power on with 100 A primary current.
High temperature operating endurance	ISO16750-4	85°C, 6000 hr, power on with 100 A primary current. Performance test before and after test only at 25°C and V_s nom.
Powered thermal cycle endurance	ISO16750-4	8 hr at 120 cycles, 960 hr. Performance test before and after test only at 25°C and V_s nom.
Thermal shock	IEC60068-2-14	-40°C (30 min soak)/85°C (30 min soak), 250 cycles
Thermal humidity cycle	IEC 60068-2-38	240 hr, -10°C/65°C, 93 % humidity between rise in temperature and constant temperature zone, 80 % humidity in drop temperature zone. Performance test before and after test only at 25°C and V_s nom.
High temperature and humidity endurance	IEC60068-2-67	85°C, 85 % humidity, 1000 hr, power on with 100 A primary current. Performance test before and after test only at 25°C and V_s nom.
Vibration	IEC60068-2-64	5 Hz to 2000 Hz, 20 hr/axis, 3 axis with -40°C/85°C temperature cycle during test. Product power on with 100 A primary current. Performance test before and after test only at 25°C and V_s nom.
Mechanical shock	ISO16750-3	500 m/s, 2,20 each direction (60 total), half sine pulse. Product power on with 100 A primary current. Performance test before and after test only at 25°C and V_s nom.
Package drop	ISTA-1A or GB/T 4857.5	With final packaging, drop in direction at 1 corner, 3 edge, 4 face \geq total 9 drops, 1 m on concrete floor.
Handling drop	ISO 16750-3	1st fall of each DUT at a different dimensional axis, 2nd fall with the given DUT at the same dimensional axis but on the opposite side of the housing, from 1 m on concrete floor. Performance test before and after test only at 25°C and V_s nom.
Dust (and other solid intrusion)	ISO20653	IP category: 4
Water intrusion	—	Not tested. IP category: 0. Not protected.
Dew formation test	—	—
Mixed flowing gas	—	Not tested.
Salt fog	ISO16750-4 or GB/T2423.17	5 % salt water solution, 96 hr at 35°C. Performance test before and after test only at 25°C and V_s nom.
Chemical exposure (outside cabin compartment)	—	Not tested.

FLUX GATE CURRENT SENSORS

CSNV700 SERIES

TABLE 10. ELECTRICAL TEST SPECIFICATIONS

Test	Standard	Procedure
Supply voltage range	ISO 16750-2	7 V to 18 V, at 25°C, with 100 A primary current
Supply voltage ripple	—	—
Supply voltage drop out	—	—
Supply voltage dips	—	—
Slow decrease and increase of supply voltage	ISO 16750-2	Power supply changes from 18 V to 0 V with 0.5 V ±0.1 V step. At any step, power supply maintain 1 min. Power supply changes from 0 V to 18 V with 0.5 V ±0.1 V step. At any step, power supply maintain 1 min. Performance test before and after test only at 25°C and V _S nom.
Defective regulation (full-fielded alternator)	—	—
Jump start	—	Refer to "Overvoltage".
Load dump	—	32 V, 400 mSec, 5 pulses
Overvoltage	ISO 16750-2	18 V, 60 min at 85°C, 24 V for 10 min at 25°C
Reverse supply voltage	ISO 16750-2	-50 V, 10 min
Superimposed alternating voltage	ISO 16750-2	Conduct test as per ISO 16750-2 4.4. Test voltage US max 18 V for UN = 12 V systems, ac voltage (sinusoidal), severity 2, UPP = 4 V. Performance test before and after test only at 25°C and V _S nom.
Discontinuities in supply voltage	ISO 16750-2	Conduct test as per ISO 16750-2 4.6. Momentary drop in supply voltage reset behavior at voltage drop starting profile.
Immunity to short circuits in the supply voltage input and load output lines	—	See "Short circuit protection".
Immunity to short circuits in I/O signal lines	—	See "Short circuit protection".
Short circuit protection	ISO 16750-2	Sensor supply of 18 Vdc and 24 Vdc. Connect CAN-H and GND and hold for 60 s. Connect CAN-L and GND and hold for 60 s. Connect CAN-H and V _S and hold for 60 s. Connect CAN-L and V _S and hold for 60 s. Performance test before and after test only at 25°C and V _S nom.
Insulation resistance	ISO 16750-2	Test voltage: 500 Vdc ±10 Vdc between primary bar and the short-circuited secondary circuit. Test duration: 60 s, insulation resistance ≥500 MΩ
ac dielectric voltage test	IEC60664-1	Test voltage: 5000 Vac, test voltage frequency: 50 Hz to 60 Hz, test duration: 60 s, leakage current ≤1 mA
dc dielectric voltage test	IEC60664-1	Test voltage: 5000 Vdc, test duration: 60, leakage current ≤1 mA
High current transient shock test	—	Product power on with 12 V supply voltage. Monitor product CAN bus output and power supply current. Apply primary transient current shock at 2000 A, 5000 A, 7000 A, 9000 A, 10000 A Performance test before and after test only at 25°C and V _S nom.

WARRANTY/REMEDY

Honeywell warrants goods of its manufacture as being free of defective materials and faulty workmanship during the applicable warranty period. Honeywell's standard product warranty applies unless agreed to otherwise by Honeywell in writing; please refer to your order acknowledgment or consult your local sales office for specific warranty details. If warranted goods are returned to Honeywell during the period of coverage, Honeywell will repair or replace, at its option, without charge those items that Honeywell, in its sole discretion, finds defective.

The foregoing is buyer's sole remedy and is in lieu of all other warranties, expressed or implied, including those of merchantability and fitness for a particular purpose. In no event shall Honeywell be liable for consequential, special, or indirect damages.

While Honeywell may provide application assistance personally, through our literature and the Honeywell web site, it is buyer's sole responsibility to determine the suitability of the product in the application.

Specifications may change without notice. The information we supply is believed to be accurate and reliable as of this writing. However, Honeywell assumes no responsibility for its use.

FOR MORE INFORMATION

Honeywell services its customers through a worldwide network of sales offices and distributors. For application assistance, current specifications, pricing or the nearest Authorized Distributor, visit our [website](#) or call:

USA/Canada	+1 302 613 4491
Latin America	+1 305 805 8188
Europe	+44 1344 238258
Japan	+81 (0) 3-6730-7152
Singapore	+65 6355 2828
Greater China	+86 4006396841

Honeywell Sensing and Safety Technologies

830 East Arapaho Road
Richardson, TX 75081
www.honeywell.com

006009-1-EN | 1 | 12/22
© 2022 Honeywell International Inc. All rights reserved.

三協インタナショナル株式会社 03-3662-8100

WARNING PERSONAL INJURY

DO NOT USE these products as safety or emergency stop devices or in any other application where failure of the product could result in personal injury.

Failure to comply with these instructions could result in death or serious injury.

WARNING MISUSE OF DOCUMENTATION

- The information presented in this product sheet is for reference only. Do not use this document as a product installation guide.
- Complete installation, operation, and maintenance information is provided in the instructions supplied with each product.

Failure to comply with these instructions could result in death or serious injury.

Honeywell