

CA/04/N, NL, NH, EH Charge amplifier: 04 system

Low noise, extended low frequency response; input range, output up to 3.16V/pC, overload LED; bandwidth 0.1/100 kHz



CHARGE AMPLIFIER NOISE

The dominant source is input voltage noise, amplified by the non-inverting gain of the transducer interface section (Fig.1.). This latter is a function of the signal source impedance, $1/\omega (C_t + C_c)$, and charge amplifier transfer impedance $1/\omega C_f$ being unity (best case) for open circuit input. Note also that in the O/C input case, increased transfer impedance improves signal/noise by prorata enhancement of the inverting/no inverting gain ratio. It is safe to say that noise evaluation and comparison should be subject to representative input loading-open circuit data may mislead.

Minimal noise design centres on the choice of early stage active devices and their configuration; ergonomic facets contributing to operational versatility may override absolute minimisation.

CA/04/N

Low noise charge amplifier, with a 0.1/1Hz (-3dB) switchable minimum frequency option, provision for adding custom single pole low pass roll-off, LED overload indicator.

NORMALISING

A three decade digi-switch and x1/x10 multiplier provides output normalising over a 1/110pC/g transducer sensitivity range, with 1% worst case resolution.

Min. (1.00), max. (10.99) digi-switch settings confine range to minimum 1% resolution, caters for 10 & 100pC/g transducer nominal sensitivity tolerance spread.

OUTPUTS

Setting digi-switch and multiplier directly to the transducer charge sensitivity calibrates O/P1 to

10mV/g, O/P2 to 1V for range switches setting 0.316, 1.0, 3.16, 10, 31.6, or 100g. Normalising scale factor greater than unity produces a pro-rata gain reduction, hence O/P1 & 2 scaling, and increase in peak g.

Frequency Response – 0/P2

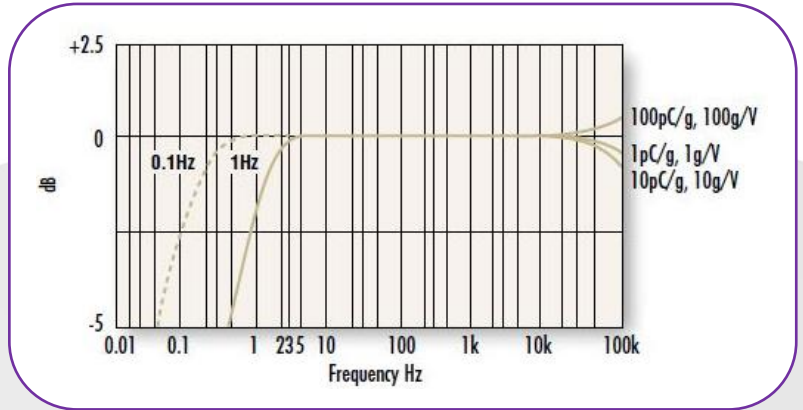

Noise level V Source capacitance

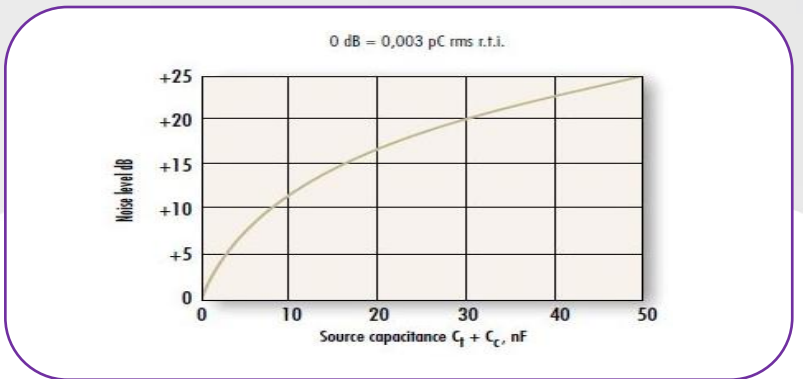

Type	Sensitivity
CA/04/NL	0.1/11pC/g
CA/04/N	1/110pC/g
CA/04/NH	10/1100pC/g
CA/04/EH	100/11000pC/g
Available for low, high or very high sensitivity accelerometers.	

CA/04/N, NL, NH, EH

Charge amplifier: 04 system

Low noise, extended low frequency response; input range, output up to 3.16V/pC, overload LED; bandwidth 0.1/100 kHz



By way of example, with the amplifier normalised to 50pC/g a 10pC/g transducer rescales O/P1 to 2mV/g peak O/P1 level will increase from 1200 to 6000g ($V_s = \pm 15V$).

OVERLOAD

Absolute value peak detector indicates signal level exceeding 8V.

CALIBRATION

The CAL terminal connects to the amplifier input (virtual earth) via a 1nF capacitor. A voltage applied to CAL converts to an input charge (1mV \equiv 1pC).

APPLICATION NOTES

Improved noise floor and extended low frequency offer performance advantages in such areas as low level structural vibration surveys. Long duration shock measurement fidelity will be improved in 0.1Hz minimum frequency mode, rectangular wave pulse duration for 10% droop increasing from 10ms to 100ms.

Fig. 1

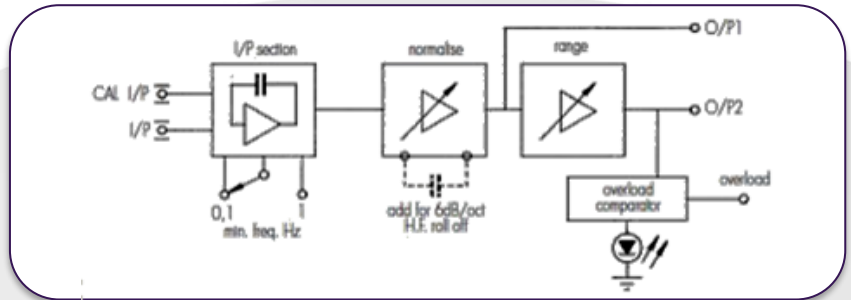
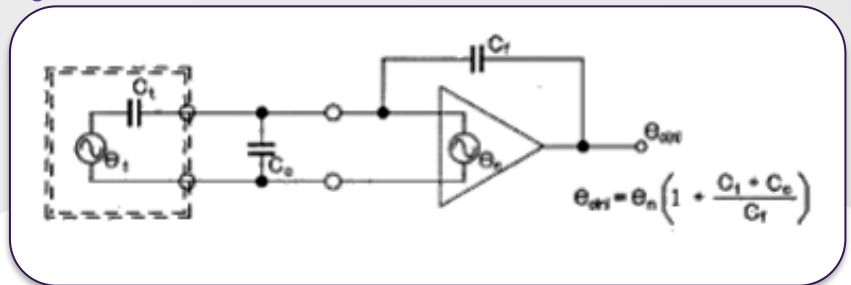

Fig. 2



CA/04/N	Metric	Imperial
Input	Single ended	
Max input charge, nC	100. reducing @ 6dB/oct. for freq > 30kHz	100. reducing @ 6dB/oct. for freq > 30kHz
Input capacitance loading	10nF = 1% gain reduction	10nF = 1% gain reduction
Normalising range	1/11pC/(m/s ²) 10/110pC/(m/s ²)	1/11 pC/g 10/110 pC/g
Noise level r.t.i.p @ 1pC/g & 1g Volt scaling	0.004pC rms + 0.004pC rms/1nF input capacitance	0.004pC rms + 0.004pC rms/1nF input capacitance
Outputs 1 & 2 • O/P1 mV/g • O/P2 g/V Switch selectable 10dB increments	Single ended 10±2% @ 500Hz 0.316, 1, 3.16, 10, 31.6, 100g/volt ±3% @ 500 Hz	Single ended 10±2% @ 500Hz 0.316, 1, 3.16, 10, 31.6, 100g/volt ±3% @ 500 Hz
Peak O/P volts @ $V_s = \pm 15V$	±12V O/P's 1 & 2	±12V O/P's 1 & 2
Peak O/P current, O/Ps 1 & 2, mA	±10	±10
Output impedance, O/Ps 1 & 2	< 10Ω + 47μF	