

## DATA SHEET

# vibro-meter®

## VE210 velocity sensor



### KEY FEATURES AND BENEFITS

- From the vibro-meter® product line
- Low-frequency compensation allows frequency response down to 0.5 Hz (-3 dB)
- Current or voltage modulated output signal
- No need for additional signal conditioner
- Long-distance signal transmission with a GSI127 galvanic separation unit
- Any sensor mounting orientation
- Top-mounted military-standard connector
- Fully sealed sensor: IP68 protection rating
- Temperature range: -25 to 80°C

### APPLICATIONS

- Designed for vibration monitoring on low-speed machines
- Suitable for hydraulic and steam turbine applications

### DESCRIPTION

The VE210 velocity sensor is designed to measure absolute vibration at low-frequencies. With a frequency response down to 0.5 Hz, it is suitable for the special monitoring requirements of hydraulic turbomachinery which generally operate at low speeds (for example, between 60 and 1000 RPM for hydroelectric turbines).

The body of the VE210 sensor includes the signal conditioner electronics, so only an EC4xx cable assembly is required to connect the power supply to the sensor and connect the sensor's output directly to the monitoring electronics.

Good sensitivity and rugged design make the VE210 suitable for all types of low-speed industrial machinery. Its stainless steel casing and watertight sealed connector allow it to withstand damp and corrosive environments.

The VE210's sensing element consists of a coil moving around a permanent magnet. This assembly produces an output voltage that is proportional to the vibration velocity.

The integrated signal conditioner contains electronic circuitry that provides low-frequency compensation that allows the sensor to operate



Information contained in this document may be subject to export control regulations of the European Union, USA or other countries. Each recipient of this document is responsible for ensuring that transfer or use of any information contained in this document complies with all relevant export control regulations. ECN N/A.

**DESCRIPTION** (continued)

below its resonant frequency. It also provides current-based or voltage-based output signals (factory configurable).

Current transmission (2-wire) can be used to transmit signals over a distance of up to 1000 m. With a current output, the VE210 sensor transmits the signal to a GSI127 galvanic separation unit, which provides effective insulation from differences in earth potential of up to 4 kV. Voltage transmission (3-wire) can be used to transmit signals over a distance of up to 200 m.

The EC4xx cables are available in lengths from 0.5 m, either with or without a flexible stainless steel hose (protection tube) for additional

mechanical protection. The EC439 is a 2-wire cable for current transmission and the EC440 is a 3-wire cable for voltage transmission. In very harsh industrial environments, the VE210 should be installed using an EC4xx with a flexible hose (protection tube).

An optional TA114 mounting adaptor is available to rigidly install the sensor to the machinery being monitored.

For specific applications, contact your local Meggitt representative.

**BLOCK DIAGRAM**

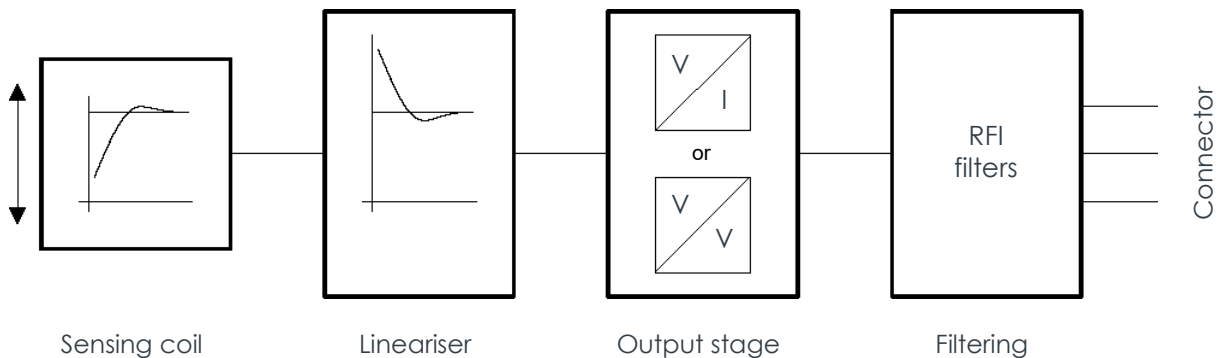

**SPECIFICATIONS**

**General**

- |                             |  |
|-----------------------------|--|
| Operating principle         | : Moving coil and magnet with integrated signal conditioner. See block diagram on page 2.                                  |
| Signal processing technique | : Low-frequency compensation by the integrated signal conditioner allows the VE210 to operate below its resonant frequency |
| Directionality              | : Sensitive to vibration along the longitudinal axis (long axis) only  |
| Signal transmission         | : Current modulated or voltage modulated output  |

**Operating**

- Sensitivity
- Current transmission (2-wire) : 50  $\mu$ A/mm/s (1270  $\mu$ A/in/s)  $\pm$ 5%
  - Voltage transmission (3-wire) : 50 mV/mm/s (1270 mV/in/s)  $\pm$ 5%

Notes: Sensitivity is given at 23°C  $\pm$ 5°C (73°F  $\pm$ 9°F) for a signal of 12.7 mm/s (0.5 in/s) at 120 Hz. The VE210 is calibrated along the longitudinal axis.

## SPECIFICATIONS *(continued)*

Dynamic measurement range	: 100 mm/s peak from 0.5 to 400 Hz
Overload capacity (spikes)	: 100 g peak
Linearity (amplitude)	: $\pm 1\%$ from 1 to 10 mm/s. : $\pm 2\%$ from 10 to 100 mm/s.
Transverse sensitivity	: 5% max. of response along sensitive axis
Frequency range	: 0.5 to 400 Hz
Frequency response	: $-30\%$ / $+5\%$ from 0.5 to 3 Hz. : $\pm 5\%$ from 3 to 400 Hz.

## Typical frequency response curves

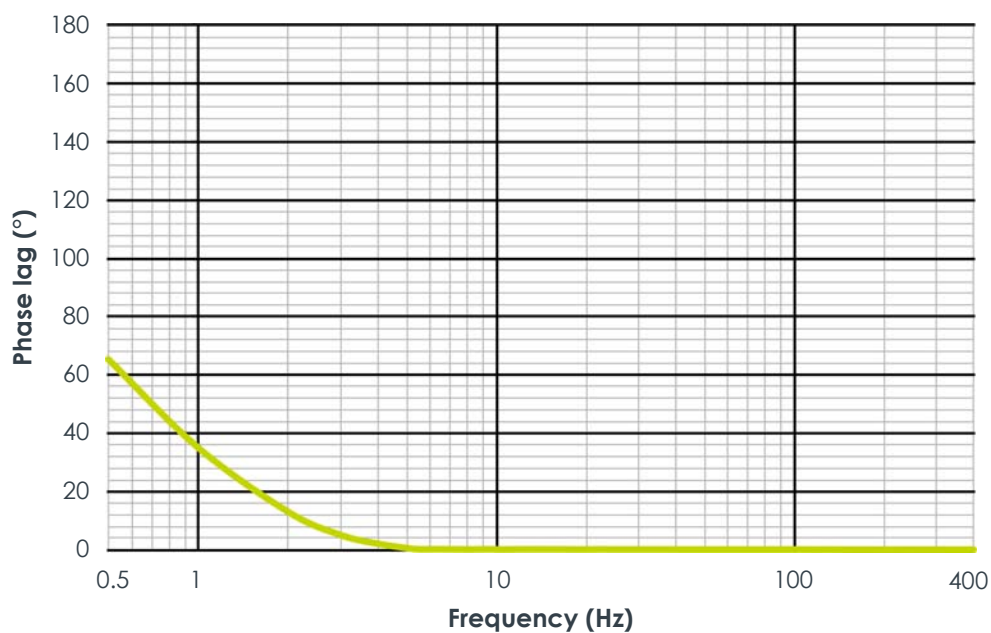
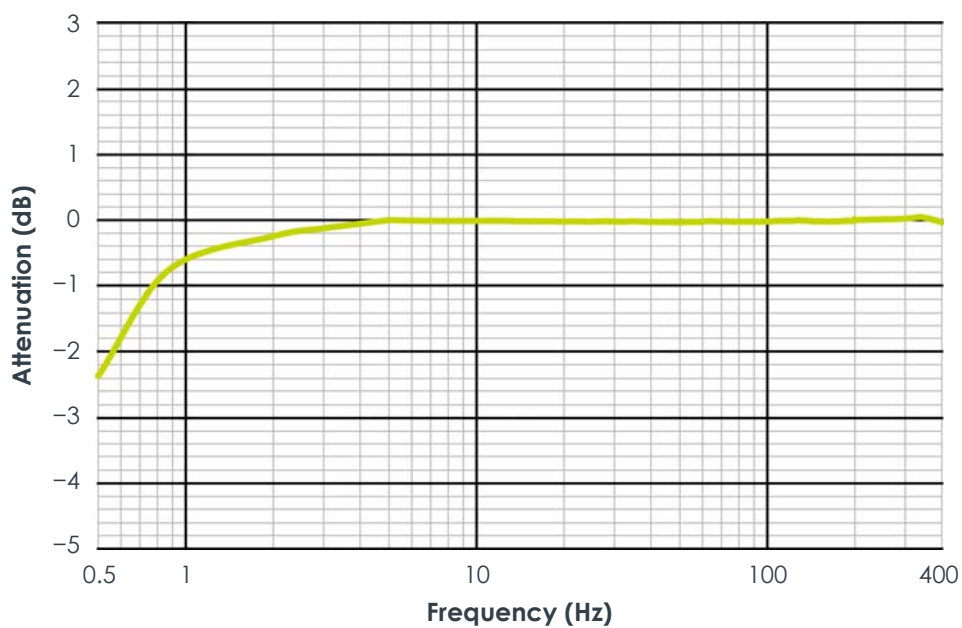

SPECIFICATIONS (continued)

Operating regions

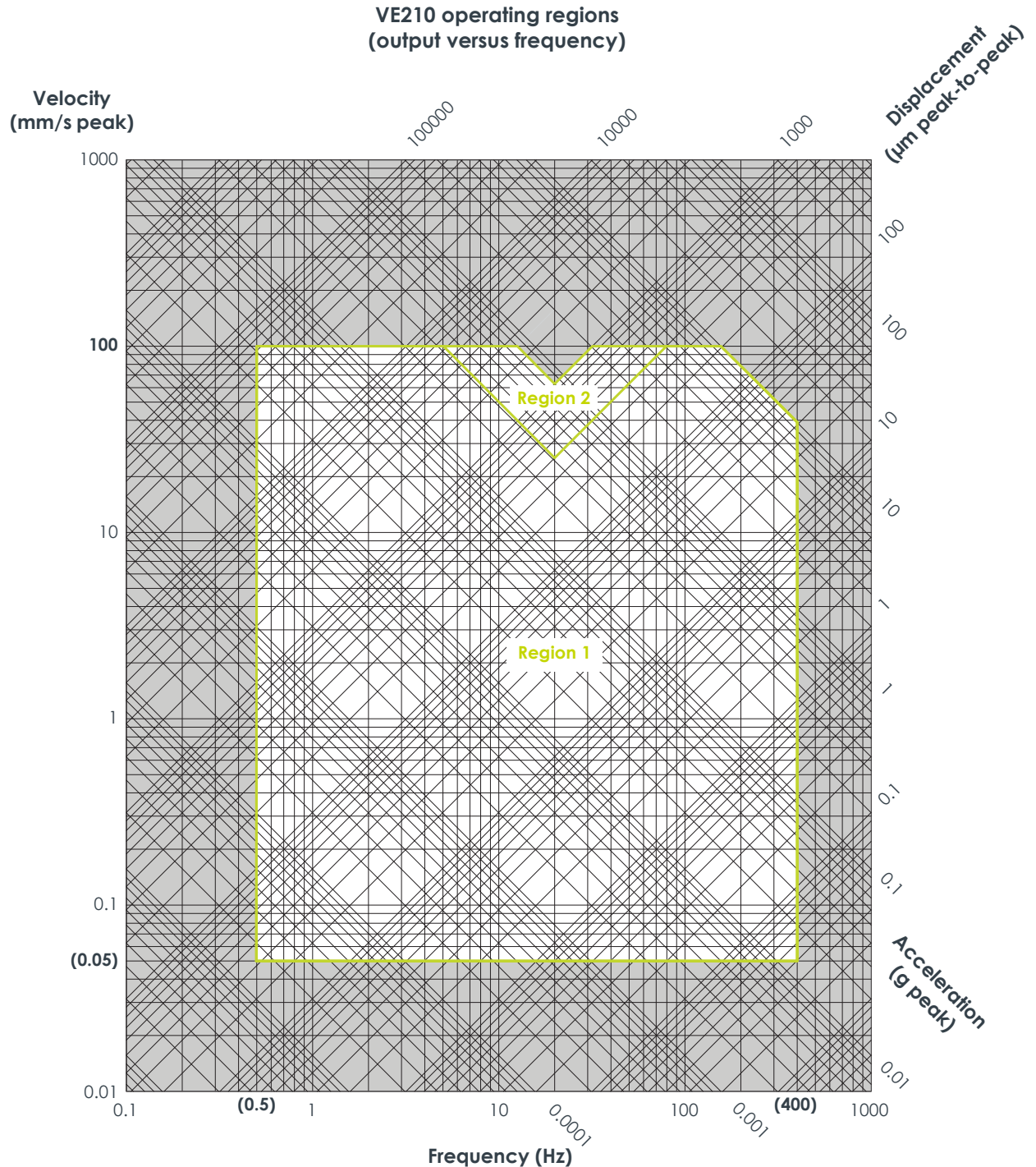

Notes

The operating region of a VE210 depends on its mounting orientation, as follows:

- Regions 1 and 2: A VE210 mounted horizontally has a slightly larger operating region that includes both Region 1 and Region 2 (as shown above).
- Region 1: A VE210 mounted vertically has a slightly smaller operating region that includes Region 1 only (as shown above).

## SPECIFICATIONS *(continued)*

---

### Environmental

Temperature range	
• Operating	: -25 to 80°C (-13 to 176°F)
• Short-term survival	: Up to 100°C (212°F)
• Storage	: -40 to 100°C (-40 to 212°F)
Humidity	: Hermetically sealed
Protection rating (according to IEC 60529)	: IP68
Shock acceleration (according to IEC 60068-2-27)	: 100 g peak (half sine-wave, 1 ms duration)

### Approvals

Conformity	: European Union (EU) declaration of conformity (CE marking). EAC marking, Eurasian Customs Union (EACU) certificate/ declaration of conformity.
Electromagnetic compatibility (EMC)	: EN 61000-6-2:2005. EN 61000-6-4:2007 + A1:2011. TR CU 020/2011.
Electrical safety	: EC 61010-1:2010
Environmental management	: RoHS compliant (2011/65/EU)
Russian federal agency for technical regulation and metrology (Rosstandart)	: Pattern approval certificate OC.C.28.004.A N° 59021

### Physical

Case (housing) material	: Stainless steel
Dimensions	: See <b>Mechanical drawings on page 7</b>
Weight	: 400 g (0.88 lb) approx.
Mounting	
• Mounting adaptor (base)	: M8 × 10 mm tapped hole or mounting adaptor. See <b>Accessories on page 8</b> .
• Mounting orientation	: Can be mounted in any direction. See <b>Mounting constraints on page 5</b> .
Connector	: Rugged circular, threaded-ring, 3-pin connector (EN 2997 series aerospace standard) with a watertight seal

### Mounting constraints

Allowed mounting orientation : Can be mounted in any direction, as shown in the drawing below

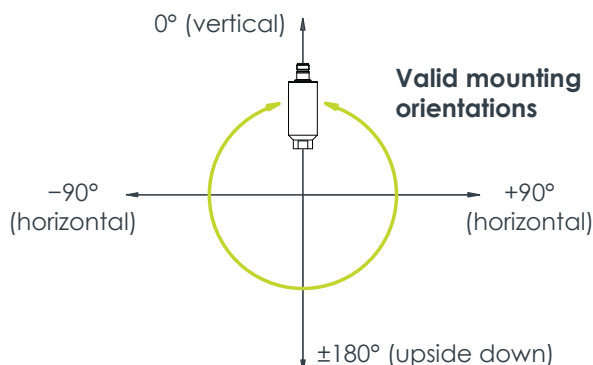

Note: The mounting orientation of a VE210 affects its operating region (see **Operating regions on page 4**).

## SPECIFICATIONS *(continued)*

---

### Signal transmission

Current output	: Current signal transmission (2-wire) supports distances up to 1000 m, with a GS1127 galvanic separation unit
• Sensitivity	: 50 $\mu$ A/mm/s
• Dynamic range	: $\pm 5$ mA max.
• Standing current	: $-12$ mA $\pm 1$ mA
• Impedance (at 100 Hz)	: $\geq 100$ k $\Omega$
Voltage output	: Voltage signal transmission (3-wire) signal transmission supports distances up to 200 m
• Sensitivity	: 50 mV/mm/s
• Dynamic range	: $\pm 5$ V max.
• Standing voltage	: $-7.5$ V <sub>DC</sub> $\pm 5\%$
• Impedance (at 100 Hz)	: 1 k $\Omega$

### Power supply

Voltage	: $-24$ V <sub>DC</sub> $\pm 25\%$ ( $-18$ to $-30$ V <sub>DC</sub> )
Current	
• Current transmission (2-wire)	: $\leq -17$ mA
• Voltage transmission (3-wire)	: $-7$ mA typ.

### Cable assemblies

Type	
• EC439	: 2-wire cable assembly for current signal transmission
• EC440	: 3-wire cable assembly for voltage signal transmission
Temperature range	: $-50$ to $120$ °C ( $-58$ to $248$ °F)
Connector	: Rugged circular, threaded-ring, 3-pin connector (EN 2997 series aerospace standard) to mate with the VE210
Optional protection	: The flexible stainless steel hose (protection tube) provides additional mechanical protection, but is not leak-tight. See <b>Accessories on page 8</b> .

MECHANICAL DRAWINGS

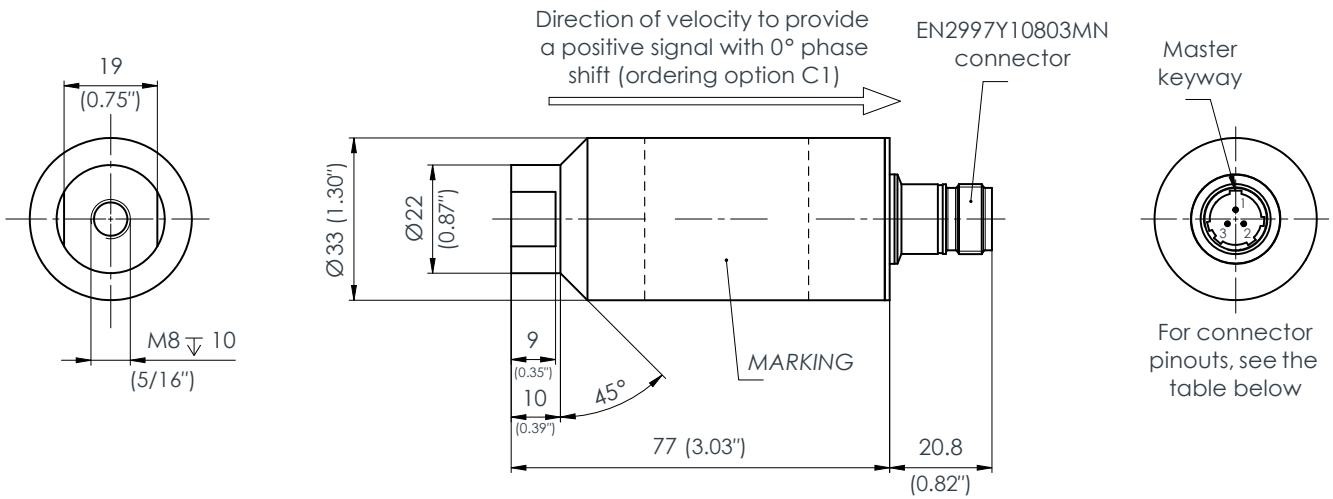

Note: All dimensions are in mm (in) unless otherwise stated.

Connector pinouts

Pin	Signal transmission	
	Current (2-wire)	Voltage (3-wire)
1	Power supply and signal output	Power supply
2	COM	COM
3	---	Output signal

ORDERING INFORMATION

To order please specify

Type  
VE210

Designation  
Velocity sensor

Ordering number (PNR)  
See below

Ordering number (PNR): 410 - 210 - 000 - 012

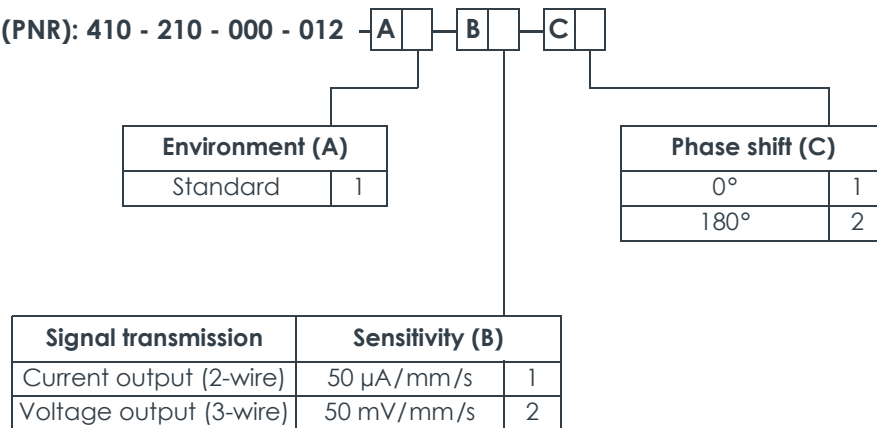

ACCESSORIES

Item	Type	Part number (PNR)
• Cable assemblies	EC439 2-wire cable assembly for current transmission: – without a flexible hose (protection tube) – with a flexible hose (protection tube). Refer to sales drawings 922-439-000D001 and 922-439-000D102 for further information.	922-439-000-001 922-439-000-102
	EC440 3-wire cable assembly for voltage transmission – without a flexible hose (protection tube) – with a flexible hose (protection tube). Refer to sales drawings 922-440-000D001 and 922-440-000D102 for further information.	922-440-000-001 922-440-000-102
Note: Cable and protection tube lengths must be specified when ordering a cable assembly.		
• Mounting adaptor	TA114 Mounting adaptor. See below and refer to product drawing 800-114-000-V011 for further information.	800-114-000-011

TA114 mounting adaptor

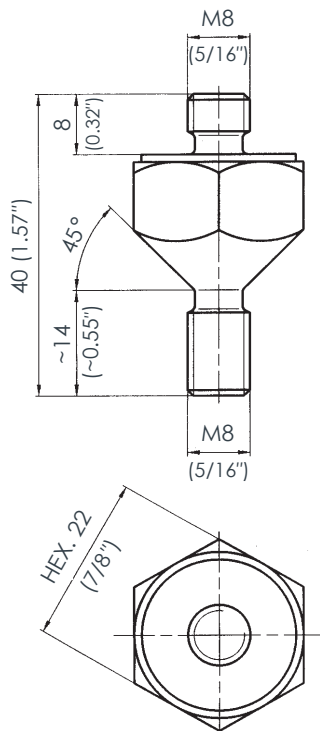

Note: All dimensions are in mm (in) unless otherwise stated.

Ordering number (PNR): 800-114-000-011



Meggitt (Meggitt PLC) is a leading international engineering company, headquartered in England, that designs and delivers high-performance components and subsystems for aerospace, defence and selected energy markets. Meggitt comprises four customer-aligned divisions: Airframe Systems, Engine Systems, Energy & Equipment and Services & Support.

The Energy & Equipment division includes the Energy Sensing and Controls product group that specialises in sensing and monitoring solutions for a broad range of energy infrastructure, and control valves for industrial gas turbines, primarily for the Power Generation, Oil & Gas and Services markets. Energy & Equipment is headquartered in Switzerland (Meggitt SA) and incorporates the vibro-meter® product line, which has over 65 years of sensor and systems expertise and is trusted by original equipment manufacturers (OEMs) globally.



All information in this document, such as descriptions, specifications, drawings, recommendations and other statements, is believed to be reliable and is stated in good faith as being approximately correct, but is not binding on Meggitt (Meggitt SA) unless expressly agreed in writing. Before acquiring and/or using this product, you must evaluate it and determine if it is suitable for your intended application. You should also check our website at [www.meggittsensing.com/energy](http://www.meggittsensing.com/energy) for any updates to data sheets, certificates, product drawings, user manuals, service bulletins and/or other instructions affecting the product.

Unless otherwise expressly agreed in writing with Meggitt SA, you assume all risks and liability associated with use of the product. Any recommendations and advice given without charge, whilst given in good faith, are not binding on Meggitt SA. Meggitt (Meggitt SA) takes no responsibility for any statements related to the product which are not contained in a current Meggitt SA publication, nor for any statements contained in extracts, summaries, translations or any other documents not authored and produced by Meggitt SA.

The certifications and warranties applicable to the products supplied by Meggitt SA are valid only for new products purchased directly from Meggitt SA or from an authorised distributor of Meggitt SA.

In this publication, a dot (.) is used as the decimal separator and thousands are separated by thin spaces. Example: 12345.67890.

Copyright© 2022 Meggitt SA. All rights reserved. The information contained in this document is subject to change without prior notice.

## Sales offices

Meggitt has offices in more than 30 countries. For a complete list, please visit our website.



## Local representative

## Head office

Meggitt SA  
Route de Moncor 4  
Case postale  
1701 Fribourg  
Switzerland  
Tel: +41 26 407 11 11  
Fax: +41 26 407 13 01  
[energy@ch.meggitt.com](mailto:energy@ch.meggitt.com)  
[www.meggittsensing.com/energy](http://www.meggittsensing.com/energy)  
[www.meggitt.com](http://www.meggitt.com)