

DATA SHEET

vibro-meter®

TQ402/TQ412, EA402 and IQS900 proximity measurement system

TQ402
(standard mount)



TQ412 (reverse mount)



IQS900



KEY FEATURES AND BENEFITS

- From the vibro-meter® product line
- Non-contact measurement system based on eddy-current principle
- Ex certified versions for use in hazardous areas (potentially explosive atmospheres)
- Conforms to API 670 recommendations
- 1, 5 and 10 m systems
- Temperature-compensated design
- Voltage or current output with protection against short circuits
- Frequency response: DC to 20 kHz (-3 dB)
- Measurement range: 2 or 4 mm
- Temperature range: -40 to +180 °C

APPLICATIONS

- Shaft relative vibration and gap/position measurement chains for machinery protection and/or condition monitoring
- Ideal for use with VM600 and/or VibroSmart® machinery monitoring systems
- API 670 applications

DESCRIPTION

The TQ402/TQ412, EA402 and IQS900 form a proximity measurement system, from Meggitt's vibro-meter® product line. This proximity measurement system allows contactless measurement of the relative displacement of moving machine elements.

TQ4xx-based proximity measurement systems are particularly suitable for measuring the relative vibration and axial position of rotating machine shafts, such as those found in steam, gas and hydraulic turbines, as well as in alternators, turbo-compressors and pumps.



Information contained in this document may be subject to export control regulations of the European Union, USA or other countries. Each recipient of this document is responsible for ensuring that transfer or use of any information contained in this document complies with all relevant export control regulations. ECN N/A.

DESCRIPTION *(continued)*

The system is based around a TQ402 or TQ412 non-contact sensor and an IQS900 signal conditioner. Together, these form a calibrated proximity measurement system in which each component is interchangeable. The system outputs a voltage or a current proportional to the distance between the transducer tip and the target, such as a machine shaft.

The active part of the transducer is a coil of wire that is moulded inside the tip of the device, made of Torton[®] (polyamide-imide). The transducer body is made of stainless steel. The target material must, in all cases, be metallic.

The transducer body is available with metric or imperial thread. The TQ412 version is intended for reverse-mount applications. Both the TQ402 and TQ412 have an integral coaxial cable, terminated with a self-locking miniature coaxial connector. Various cable lengths (integral and extension) can be ordered.

The IQS900 signal conditioner contains a high-frequency modulator/demodulator that supplies a driving signal to the transducer. This generates the necessary electromagnetic field used to measure the gap. The conditioner circuitry is made of high-quality components and is mounted in a painted aluminium housing.

Note: The IQS900 signal conditioner matches or better the outstanding measurement performance and specifications of the IQS450 signal conditioner, which it replaces. Accordingly, the IQS900 is compatible with all TQ9xx and TQ4xx proximity sensors / measurement chains.

In addition, the IQS900 signal conditioner includes improvements such as: SIL 2 "by design", improved frame-voltage immunity, improved electromagnetic immunity and emissions, smaller output impedance (voltage output), optional diagnostic circuitry (that is, built-in self-test (BIST)), raw output pin, test input pin, new DIN-rail mounting adaptor and removable screw-terminal connectors for easier installation.

The TQ402 and TQ412 transducers can be matched with a single EA402 extension cable to effectively lengthen the front-end. Optional housings, junction boxes and interconnection protectors are available for the mechanical and environmental protection of the connection between the integral and extension cables.

TQ4xx-based proximity measurement systems can be powered by associated machinery monitoring systems such as VM600 cards or VibroSmart[®] modules, or by another power supply.

For specific applications, contact your local Meggitt representative.

SPECIFICATIONS

Overall proximity measurement system

Operation

Sensitivity

- *Ordering option B21* : 8 mV/ μ m (200 mV/mil)
- *Ordering option B22* : 2.5 μ A/ μ m (62.5 μ A/mil)
- *Ordering option B23* : 4 mV/ μ m (100 mV/mil)
- *Ordering option B24* : 1.25 μ A/ μ m (31.2 μ A/mil)

Linear measurement range (typical)

- *Ordering option B21* : 0.15 to 2.15 mm, corresponding to a -1.6 to -17.6 V output
- *Ordering option B22* : 0.15 to 2.15 mm, corresponding to a -15.5 to -20.5 mA output
- *Ordering option B23* : 0.3 to 4.3 mm, corresponding to a -1.6 to -17.6 V output
- *Ordering option B24* : 0.3 to 4.3 mm, corresponding to a -15.5 to -20.5 mA output

Linearity

: See **Performance curves on page 6 and on page 7**

Frequency response

: DC to 20 kHz (-3 dB)

Interchangeability of elements

: All components in system are interchangeable

SPECIFICATIONS *(continued)*

Environmental

Potentially explosive atmospheres

Available in Ex approved versions for use in hazardous locations

TQ402/TQ412 and EA402

Type of protection Ex i: intrinsic safety (ordering option A2)		
Europe	EC type examination certificate	LCIE 11 ATEX 3091 X II 1G (Zones 0, 1, 2) Ex ia IIC T6...T3 Ga
International	IECEx certificate of conformity	IECEx LCI 11.0061X Ex ia IIC T6...T3 Ga
North America	cCSAus certificate of compliance	cCSAus 1514309 Class I, Divisions 1 and 2, Groups A, B, C, D Ex ia
South Korea	KGS certificate of conformity	KGS 15-GA4BO-0664X Ex ia IIC T6 to T3
Russian Federation	EAЭC RU certificate of conformity	EAЭC RU C-CH.AΔ07.B.03003/21 0Ex ia IIC T6...T3 Ga X
India	PESO approval certificate*	PESO A/P/HQ/WB/104/5575 (P447944) Ex ia IIC T6...T3 Ga

Type of protection Ex nA: non-sparking (ordering option A3)		
Europe	Voluntary type examination certificate	LCIE 11 ATEX 1010 X II 3G (Zone 2) Ex nA II T6...T3 Gc
International	IECEx certificate of conformity	IECEx LCI 11.0063X Ex nA II T6...T3 Gc
North America	cCSAus certificate of compliance	cCSAus 1514309 Class I, Division 2, Groups A, B, C, D
Russian Federation	EAЭC RU certificate of conformity**	EAЭC RU C-CH.AΔ07.B.03003/21 2Ex nA II T6...T3 Gc X

* Not engraved/marked on the products.

** Not engraved/marked on all products.



 **For specific parameters of the mode of protection concerned and special conditions for safe use, refer to the Ex certificates that are available from Meggitt SA.**

 **For the most recent information on the Ex certifications that are applicable to this product, refer to the Ex product register (PL-1511) document that is available from Meggitt SA.**

SPECIFICATIONS *(continued)*

IQS900

Type of protection Ex: (ordering option code A5)		
Europe	EC type examination certificate	<i>Pending</i>
International	IECEx certificate of conformity	<i>Pending</i>
North America	cCSAus certificate of compliance	<i>Pending</i>
South Korea	KGS certificate of conformity	<i>Pending</i>
Russian Federation	TR CU certificate of conformity	<i>Pending</i>

-  **For specific parameters of the mode of protection concerned and special conditions for safe use, refer to the Ex certificates that are available from Meggitt SA.**
-  **For an IQS900 signal conditioner with protection mode “Ex” located in an Ex Zone 2, the user must ensure that the IQS900 is installed in an industrial housing or enclosure that ensures a protection rating of at least IP54 (or equivalent).**
-  **For the most recent information on the Ex certifications that are applicable to this product, refer to the *Ex product register (PL-1511)* document that is available from Meggitt SA.**

Approvals

- Conformity : CE marking, European Union (EU) declaration of conformity.
EAC marking, Eurasian Customs Union (EACU) certificate/
declaration of conformity.
- Electromagnetic compatibility
 - TQ402/TQ412 and EA402 : EN 61000-6-2:2005.
EN 61000-6-4:2007 + A1:2011.
TR CU 020/2011.
 - IQS900 : EN 61000-6-2:2005.
EN 61000-6-4:2007 + A1:2011.
EN 61326-1:2013.
EN 61326-3-2:2008 (SIL).
- Electrical safety : EN 61010-1:2010
- Environmental management : RoHS compliant (2011/65/EU)
- Hazardous areas : Ex approved versions
(see **Potentially explosive atmospheres starting on page 3**)
- Russian federal agency for technical regulation and metrology (Rosstandart) : Pattern approval certificate CH.C.28.004.A N° 58976.
(Note: TQ402/TQ412 and EA402.)

Note: Some approvals/certifications are pending.

SPECIFICATIONS *(continued)*

System calibration

Calibration temperature	: +23°C ±5°C
Target material	: VCL 140 steel (1.7225)

Note: For applications using a non-standard or special target material, performance curves can be generated and supplied. Contact Meggitt SA for further information.

Total system length

The total system length (TSL) is the sum of the length of the TQ4xx transducer's integral cable and the length of the EA40x extension cable. The supported TSLs can be obtained from different combinations of cables.

Total system lengths

• 1 m	: 1.0 m integral cable with no extension cable
• 5 m	: 0.5 m integral cable + 4.5 m extension cable. 1.0 m integral cable + 4.0 m extension cable. 1.5 m integral cable + 3.5 m extension cable. 2.0 m integral cable + 3.0 m extension cable. 5.0 m integral cable with no extension cable.
• 10 m	: 0.5 m integral cable + 9.5 m extension cable. 1.0 m integral cable + 9.0 m extension cable. 1.5 m integral cable + 8.5 m extension cable. 2.0 m integral cable + 8.0 m extension cable. 5.0 m integral cable + 5.0 m extension cable. 10.0 m integral cable with no extension cable.

Note: The combination of cables selected for a particular total system length depends on the application. For example, to obtain the optimum location for the separation between the integral and extension cables or to eliminate the requirement for an extension cable.

Total system length trimming

Due to the characteristics of the coaxial cable, an "electrical trimming" of the nominal length of extension cables is necessary to optimize the system performance and the transducer interchangeability.

TSL for a 1 m measurement chain	: 0.9 m minimum
TSL for a 5 m measurement chain	: 4.4 m minimum
TSL for a 10 m measurement chain	: 8.8 m minimum

SPECIFICATIONS (continued)

Performance curves for TQ402 or TQ412 with IQS900 – 2 mm measurement range

Typical gap error (μm)
(Referenced to 8 mV/ μm
(2.5 $\mu\text{A}/\mu\text{m}$) line)

Typical sensitivity error
(Referenced to 8 mV/ μm
(2.5 $\mu\text{A}/\mu\text{m}$))

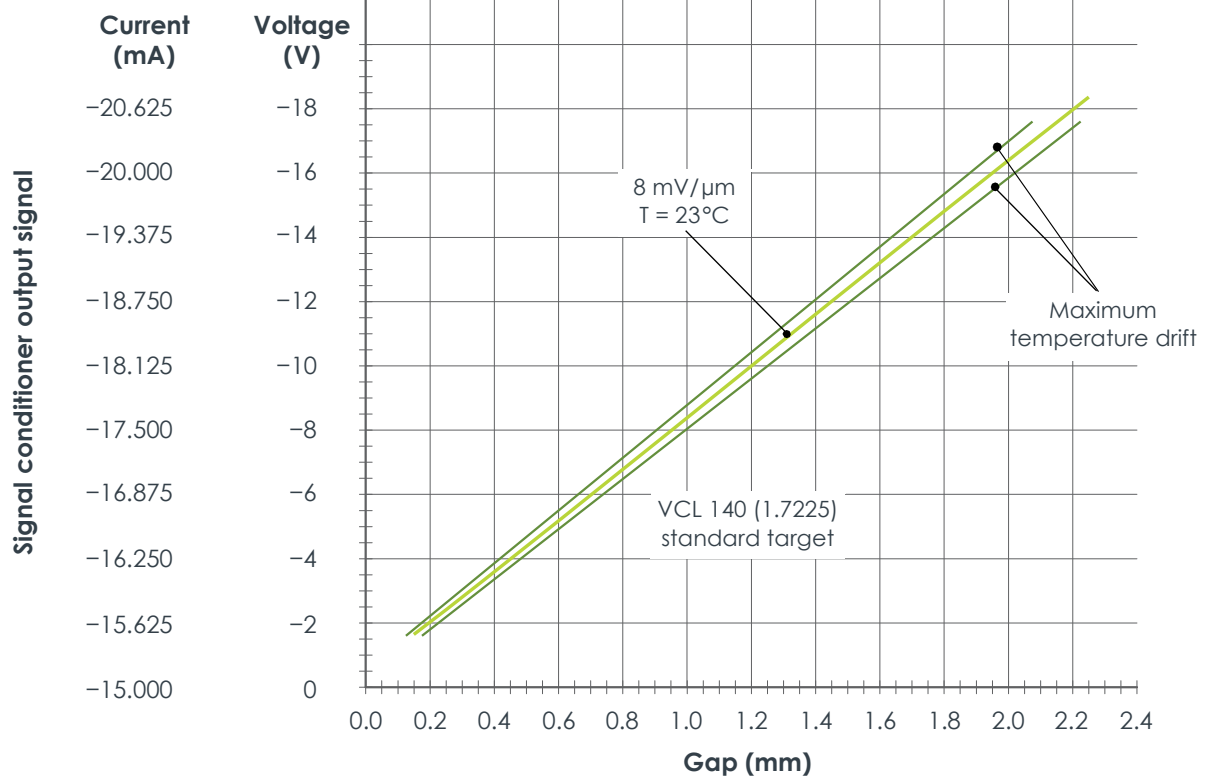

Proximity transducer: TQ402 or TQ412
 Signal conditioner: IQS900 (ordering option code B21 or B22)
 Standard target material: VCL 140 (1.7225)
 Equivalent materials: A 37.11 (1.0065), AFNOR 40 CD4, AISI 4140

SPECIFICATIONS (continued)

Performance curves for TQ402 or TQ412 with IQS900 – 4 mm measurement range

Typical gap error (μm)
(Referenced to 4 mV/ μm
(1.25 $\mu\text{A}/\mu\text{m}$) line)

Typical sensitivity error
(Referenced to 4 mV/ μm
(1.25 $\mu\text{A}/\mu\text{m}$))

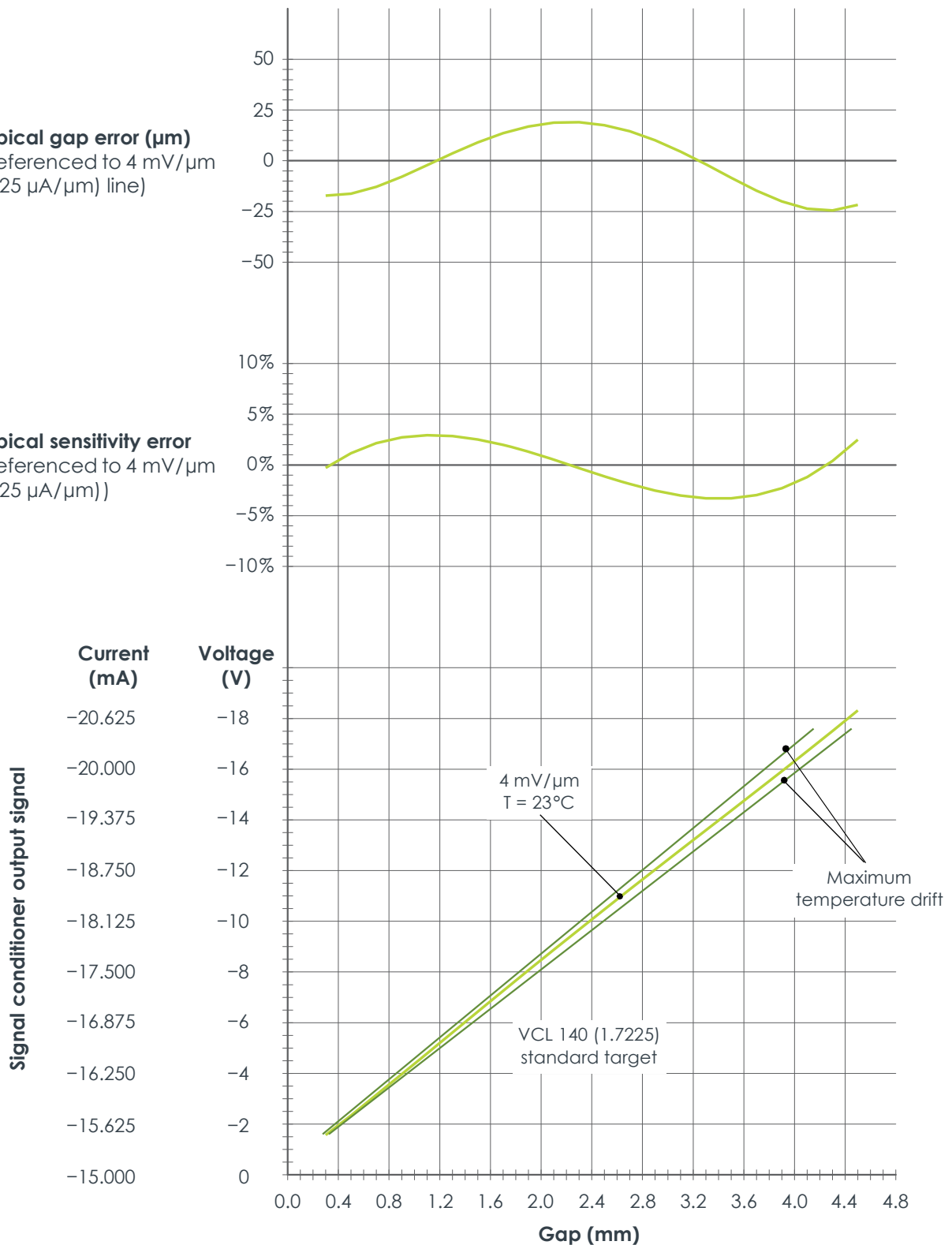

Proximity transducer: TQ402 or TQ412
 Signal conditioner: IQS900 (ordering option code B23 or B24)
 Standard target material: VCL 140 (1.7225)
 Equivalent materials: A 37.11 (1.0065), AFNOR 40 CD4, AISI 4140

SPECIFICATIONS *(continued)*

TQ402 and TQ412 proximity transducers and EA402 extension cable

General

Transducer input requirements : High-frequency power source from an IQS900 signal conditioner

Environmental

Temperature ranges

- Transducer : -40 to +180°C with drift <5% (operating).
+180 to +220°C with drift >5% (short-term survival).
 - Transducer and cable : **-40 to +195°C if used in an Ex Zone**
 - Cable, connector and optional protection : -40 to +200°C
- Protection rating (according to IEC 60529) : The head of the proximity transducer (transducer tip and integral cable) is rated IP68
- Vibration (according to IEC 60068-2-26) : 5 g peak between 10 and 500 Hz
- Shock acceleration (according to IEC 60068-2-27) : 15 g peak (half sine-wave, 11 ms duration)

Physical characteristics

- Transducer construction : Wire coil Ø8 mm, Torlon (polyamide-imide) tip, encapsulated in stainless steel body (AISI 316L) with high-temperature epoxy glue
- Integral and extension cables : FEP covered 70 Ω coaxial cable, Ø3.6 mm
- Connectors : Self-locking miniature coaxial connectors.
Note: When connecting, these should be hand-tightened until locked.
- Optional protection
- *Flexible stainless steel hose (protection tube)* : The stainless steel hose provides additional mechanical protection but is not leak-tight
 - *FEP sheath (extruded fluorinated ethylene propylene)* : The FEP sheath provides resistance to almost all chemicals and low permeability to liquids, gases and moisture. It is also flexible, low friction and mechanically tough.

SPECIFICATIONS *(continued)*

IQS900 signal conditioner

Current output (2-wire signal transmission)

Current at min. / max. gap	: -15.5 mA / -20.5 mA
Measurement range	: 5 mA (corresponding to 2 or 4 mm)
Output sensitivity	: See Operation on page 2 and IQS900 signal conditioner on page 15
Nominal output signal	
• Without diagnostics	: -15.5 to -20.5 mA
• With diagnostics	: -15.5 to -20.5 mA indicates normal operation. Other current values (>-15.5 or <-20.5 mA) indicate a problem with the measurement chain (sensor, cabling and/or signal conditioner).
Output impedance	: >60 k Ω . Note: Recommended monitoring system input impedance: ≤ 350 Ω .

Voltage output (3-wire signal transmission)

Voltage at min. / max. gap	: -1.6 V / -17.6 V
Measurement range	: 16 V (corresponding to 2 or 4 mm)
Output sensitivity	: See Operation on page 2 and IQS900 signal conditioner on page 15
Nominal output signal	
• Without diagnostics	: -1.6 to -17.6 V
• With diagnostics	: -1.6 to -17.6 V indicates normal operation. Other current values (>-1.6 or <-17.6 V) indicate a problem with the measurement chain (sensor, cabling and/or signal conditioner).
Output impedance (small signal)	: <100 Ω at DC. <300 Ω at 20 kHz. Note: Recommended monitoring system input impedance: ≥ 50 k Ω . The low output impedance enables operation with a wider range of galvanic separation units / safety barriers, without loss of performance. For example, an IQS900 (output impedance 100 Ω) connected to a third-party galvanic isolator (input impedance 10 k Ω) will see 1% max. signal loss due to impedance matching.
Protection	: Short-circuit (35 mA), overvoltage (33 V)
Output voltage swing	: -0.05 to -22.5 V with a 50 k Ω load and a -24 V _{DC} power supply. -0.05 to -21.5 V with a 10 k Ω load and a -24 V _{DC} power supply.

Raw output (RAW/COM)

Output voltage range	: -0.8 to -8.8 V (nominal)
Output impedance	: <15 k Ω up to 20 kHz. <10 k Ω for DC measurement. Note: Recommended test equipment input impedance: >1 M Ω .
Protection	: Short-circuit, overvoltage (33 V)

Test input (TEST/COM)

Input voltage range	: ± 0.1 to 4.0 V _{PK-PK} (nominal), depending on the measured gap (DC)
Input impedance	: 500 k Ω . Note: Recommended test equipment output impedance: >5 k Ω .
Protection	: Overvoltage (33 V)

SPECIFICATIONS *(continued)*

Power supply (to IQS900)

Input voltage range

- Nominal : $-24 V_{DC} \pm 25\%$ (-18 to $-30 V_{DC}$)
- With a current output : -17.4 to $-30.6 V_{DC}$.
(2-wire signal transmission) -18 to $-30 V_{DC}$ (nominal).
- With a voltage output : -18.4 to $-30.6 V_{DC}$.
(3-wire signal transmission) -19 to $-30 V_{DC}$ (nominal).

Current consumption : 25 mA max.
(with nominal $24 V_{DC}$ supply)

Overvoltage protection : Yes

Note: The IQS900 should be powered (energised) using a limited-power, low-voltage power supply such as a sensor power supply output provided a VM600 or VibroSmart[®] monitoring and/or protection system, a GS1127 galvanic separation unit or other suitable power supply.

In safety-related applications, an IQS900 must be powered using a limited-power, low-voltage power supply with a safe limitation of $-35 V_{DC}$, even in the event of a single fault with the power supply.

Environmental

Temperature

- Operating and storage : -40 to 85°C (-40 to 185°F)

Humidity : 0 to 95%, non-condensing

Protection rating : IP20.

(according to IEC 60529)

Note: The IQS900 is suitable for indoor use only unless it is installed in an industrial housing or enclosure that ensures a higher level of environmental protection.

Flammability : UL94 V-0

Vibration : 5 g peak between 10 and 500 Hz

(according to IEC 60068-2-6)

Shock acceleration : 15 g peak (half sine-wave, 11 ms duration)

(according to IEC 60068-2-27)

Connectors

Self-locking miniature coaxial connector (bidirectional) : 1 contact for sensor-side signal:
sensor (connects to TQ9xx sensor or EA902 cable)

Screw-terminal connector (input) : 4 contacts for test signals:
raw output (RAW/COM) and
test input (TEST/COM)

Screw-terminal connector (output) : 4 contacts for monitor-side signals:
measurement output (O/P/COM) and
power supply input ($-24\text{V}/\text{COM}$)

Screw-terminal connectors

- Clamping range (min. to max.) : 0.2 to 1.5 mm² (24 to 16 AWG)
- Tightening torque (min. to max.) : 0.2 to 0.25 N•m (0.15 to 0.18 lb-ft)

Note: The IQS900 features removal screw-terminal connectors that can unplugged from the main body of its housing to simplify installation and mounting.

SPECIFICATIONS *(continued)*

Physical characteristics

Electrical connections	: Self-locking miniature coaxial connector and removable screw-terminal connectors (see Connectors on page 10)
Housing material	: Injection-moulded aluminium, painted
Dimensions	: See Mechanical drawings and ordering information on page 15
Weight	: 200 g (0.44 lb) approx.
Mounting	
• Without DIN-rail mounting adaptor	: Two M4 screws
• With DIN-rail mounting adaptor (ordering option code G2)	: MA130 DIN-rail mounting adaptor for IPC707 and IQS900 signal conditioners. Suitable for TH 35 DIN rails (according to EN 50022 / IEC 60715). For example, TH 35-7.5 or TH 35-15. See Accessories on page 16 .

MECHANICAL DRAWINGS AND ORDERING INFORMATION

TQ402 proximity transducer

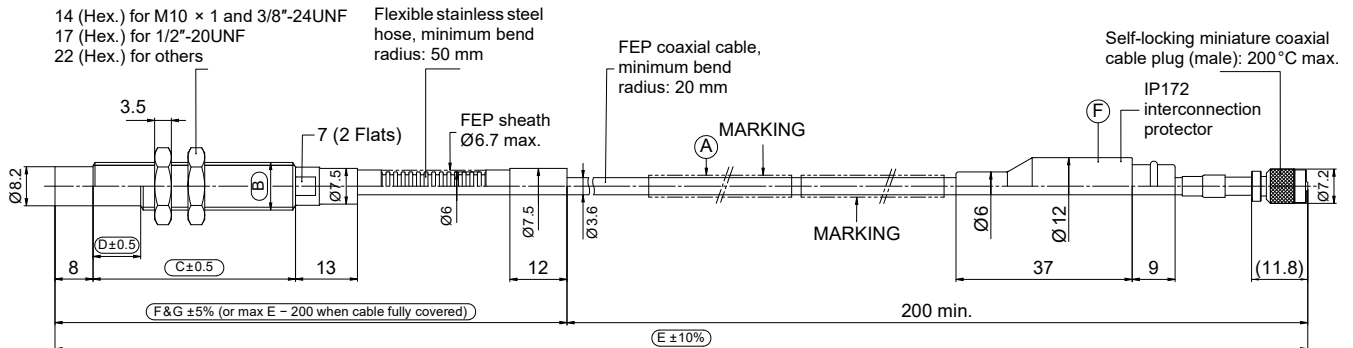

Ordering number:

111 - 402 - 000 - 013 - A - B - C - D - E - F - G - H

Environment (A)	
Standard	1
Explosive Ex i	2
Explosive Ex nA	3

Body thread (B)	
M10 × 1	1
M14 × 1.5	2
M16 × 1.5	3
3/8"-24UNF	6
5/8"-18UNF	7
1/2"-20UNF	8

Body length (C)	
Each 1 mm, from 20 to 250 mm	
20 mm min.	020
250 mm max.	250

Unthreaded length (D)	
Each 1 mm, from 0 to 230 mm	
0 mm min.	000
230 mm max.	230

Integral cable length (E)	
0.5 m ± 50 mm	005
1.0 m ± 100 mm	010
1.5 m ± 150 mm	015
2.0 m ± 200 mm	020
5.0 m ± 500 mm	050
10 m ± 1000 mm	100

Total system length (H)	
See note 2	
01	1 m
05	5 m
10	10 m

Flexible hose length (G)	
See note 1	
Each 0.1 m, from 0 to 9.8 m. G min. = C + 100 mm.	
000	None
001	0.1 m min.
098	9.8 m max.

Optional protection (F)		
See note 1		
	Cable	Connector

0	None	None
1	Flexible hose	None
2	Flexible hose with FEP sheath	None
3	Movable flexible hose	None
4	Movable flexible hose with FEP sheath	None
5	None	IP172
6	Flexible hose	IP172
7	Flexible hose with FEP sheath	IP172
8	Movable flexible hose	IP172
9	Movable flexible hose with FEP sheath	IP172

Notes

All dimensions are in mm unless otherwise stated.

- When optional protection such as a flexible stainless steel hose with or without an FEP sheath is ordered:
Flexible hose length (G) min. = Body length (C) + 100 mm.
Flexible hose length (G) max. = Integral cable length (E) - 200 mm, for an integral cable that is protected to the maximum extent possible ("cable fully covered").
- The Total system length (H) = TQ402 integral cable length (E) + EA402 extension cable length.
For information on combining integral and extension cables to obtain a particular total system length, see **Total system length on page 5**.
For information on cable length tolerances, see **Total system length trimming on page 5**.

MECHANICAL DRAWINGS AND ORDERING INFORMATION (continued)

TQ412 proximity transducer

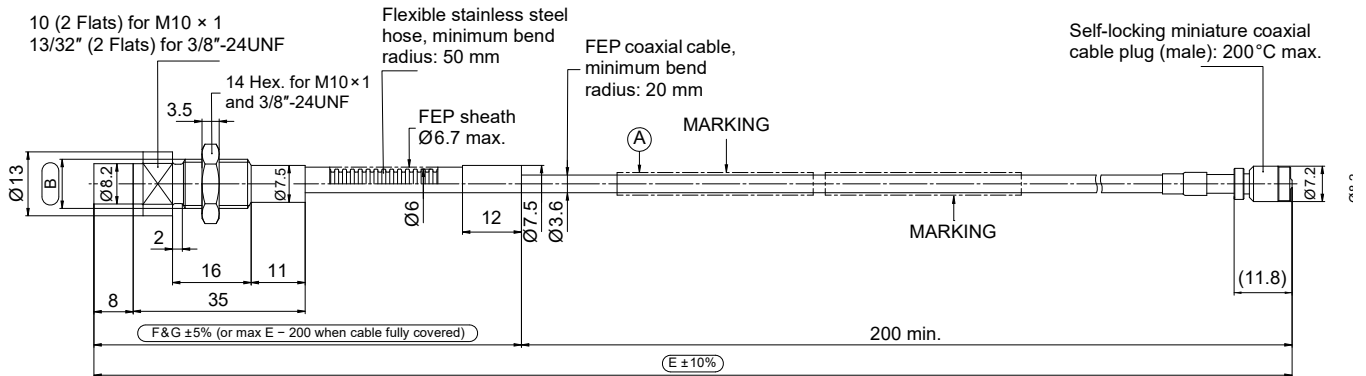

Ordering number: 111 - 412 - 000 - 013 - A B E F G H

Environment (A)	
Standard	1
Explosive Ex i	2
Explosive Ex nA	3

Body thread (B)	
M10 x 1	1
3/8"-24UNF	6

Integral cable length (E)	
0.5 m ±50 mm	005
1.0 m ±100 mm	010
1.5 m ±150 mm	015
2.0 m ±200 mm	020
5.0 m ±500 mm	050
10 m ±1000 mm	100

Optional protection (F)	
See note 1	
None	0
Flexible hose	1
Flexible hose with FEP sheath	2
Movable flexible hose	3
Movable flexible hose with FEP sheath	4

Total system length (H)	
See note 2	
01	1 m
05	5 m
10	10 m

Flexible hose length (G)	
See note 1	
Each 0.1 m, from 0 to 9.8 m	
000	None
001	0.1 m min.
098	9.8 m max.

Notes

All dimensions are in mm unless otherwise stated.

- When optional protection such as a flexible stainless steel hose with or without an FEP sheath is ordered:
Flexible hose length (G) max. = Integral cable length (E) - 200 mm, for an integral cable that is protected to the maximum extent possible ("cable fully covered").
- The Total system length (H) = TQ412 integral cable length (E) + EA402 extension cable length.
For information on combining integral and extension cables to obtain a particular total system length, see **Total system length on page 5**. For information on cable length tolerances, see **Total system length trimming on page 5**.

MECHANICAL DRAWINGS AND ORDERING INFORMATION (continued)

EA402 extension cable

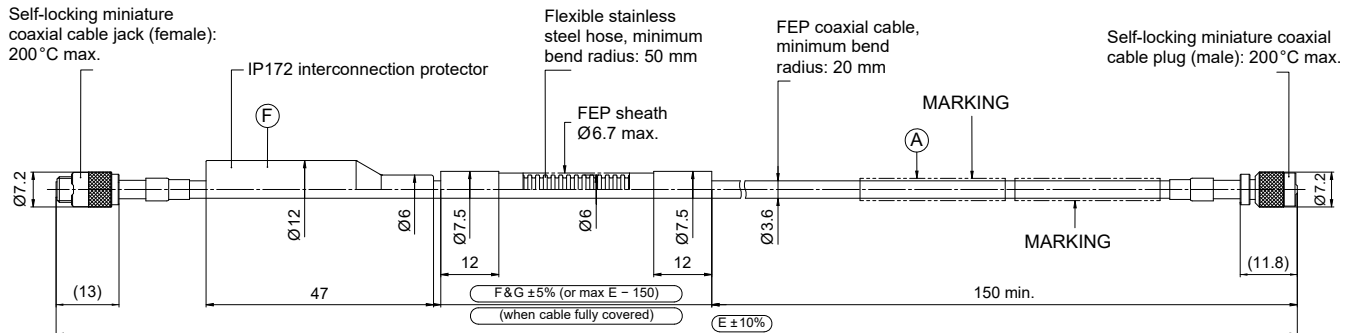

Ordering number: 913 - 402 - 000 - 013 - **A** - **E** - **F** - **G**

Environment (A)	
Standard	1
Explosive Ex i	2
Explosive Ex nA	3

Extension cable length (E) See note 1	
3.0 m ±300 mm	030
3.5 m ±350 mm	035
4.0 m ±400 mm	040
4.5 m ±450 mm	045
5.0 m ±500 mm	050
8.0 m ±800 mm	080
8.5 m ±850 mm	085
9.0 m ±900 mm	090
9.5 m ±950 mm	095

Flexible hose length (G)	
Each 0.1 m, from 0 to 9.3 m	
000	None
001	0.1 m min.
093	9.3 m max.

Optional protection (F) See note 2		
Cable	Connector	
None	None	0
Flexible hose	None	1
Flexible hose with FEP sheath	None	2
None	IP172	5
Flexible hose	IP172	6
Flexible hose with FEP sheath	IP172	7

Notes

All dimensions are in mm unless otherwise stated.

1. The total system length = TQ402 or TQ412 integral cable length + EA402 extension cable length (E).

For information on combining integral and extension cables to obtain a particular total system length, see

Total system length on page 5. For information on cable length tolerances, see **Total system length trimming on page 5.**

2. When optional protection such as a flexible stainless steel hose with or without an FEP sheath is ordered:

Flexible hose length (G) max. = EA402 extension cable length (E) - 150 mm, for an extension cable that is protected to the maximum extent possible ("cable fully covered").

MECHANICAL DRAWINGS AND ORDERING INFORMATION (continued)

IQS900 signal conditioner

Side and top views

Note: All dimensions in mm (in) unless otherwise stated.

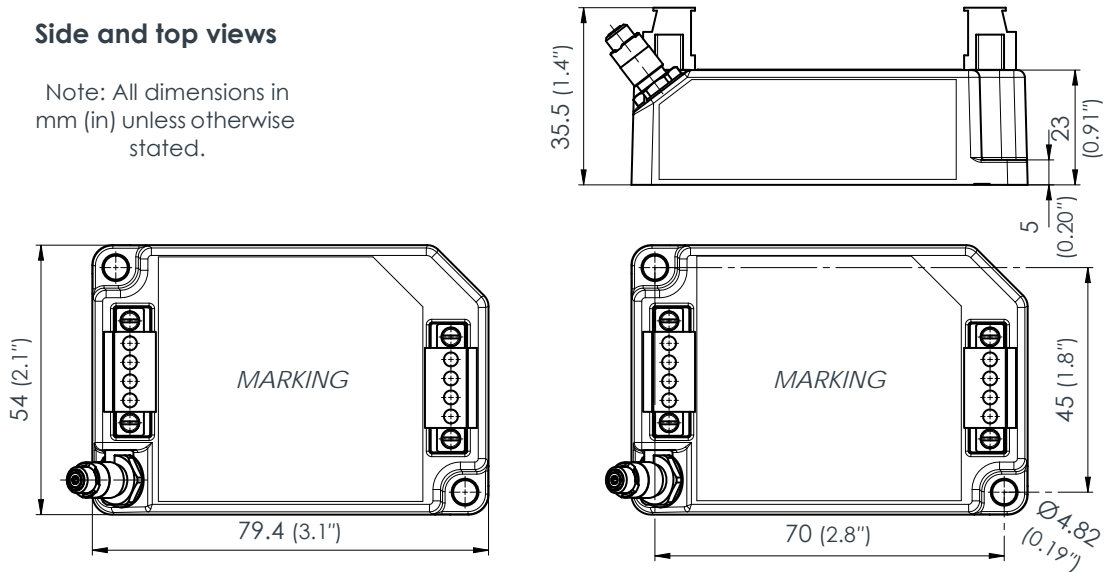

Side and end views with DIN-rail mounting adaptor (ordering option code G2)

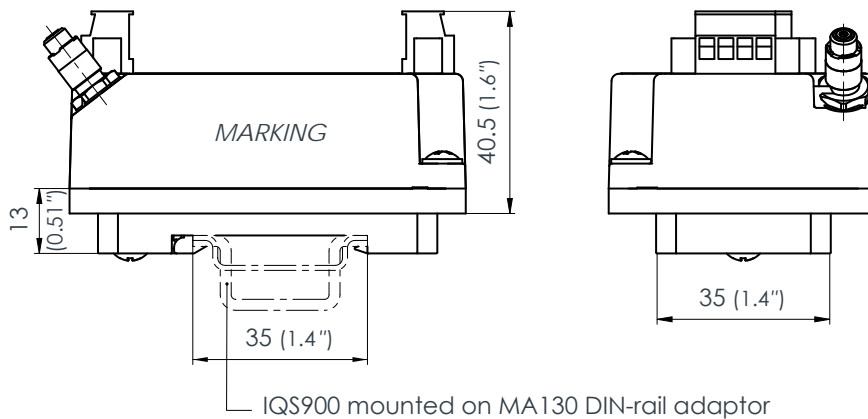

Ordering number: 204 - 900 - 000 - 011 - A - B - C - H - I

Environment (A) ¹	
Standard	1
Explosive (Ex)	5

Measurement range	Sensitivity (B)	
	2 mm	8 mV/μm
	2.5 μA/μm	22
4 mm	4 mV/μm	23
	1.25 μA/μm	24

Diagnostics (C) ²	
Without diagnostics	1
With diagnostics (SIL)	2

Total system length (H)	
1 m	01
5 m	05
10 m	10

Installation (I)	
Without DIN-rail adaptor	0
With DIN-rail adaptor (MA130)	1

Notes
See following page.

MECHANICAL DRAWINGS AND ORDERING INFORMATION *(continued)*

IQS900 signal conditioner *(continued)*

Notes

- Ordering option code **A5** ("Ex") specifies an IQS900 signal conditioner suitable for use in hazardous areas.
 - For an IQS900 signal conditioner with protection mode "Ex" located in an Ex Zone 2, the user must ensure that the IQS900 is installed in an industrial housing or enclosure that ensures a protection rating of at least IP54 (or equivalent).
- Ordering option code **C** specifies an IQS900 signal conditioner either without diagnostics (**C1**) or with diagnostics (**C2**):
 - An IQS900 signal conditioner without diagnostics (**C1**) is similar to the IQS45x, which it replaces. The IQS900 is a form, fit and functionally equivalent replacement that matches or better the measurement specifications of the IQS45x.
 - An IQS900 signal conditioner with diagnostics (**C2**) includes optional diagnostic circuitry that automatically detects and remotely indicates problems with the measurement chain (sensor, cabling and/or the IQS900 itself). An IQS900 with diagnostics is certified SIL 2 (IEC 61508) and PL c Cat 1 (ISO 13849) "by design" to more easily meet the requirements of safety-related applications. Contact Meggitt SA for further information.

ACCESSORIES

ABA17x	Industrial housings	: Refer to corresponding data sheet
IP172	Interconnection protection	: Refer to corresponding data sheet
JB118	Junction box	: Refer to corresponding data sheet
KS107	Flexible conduit (protection tube)	: Refer to corresponding data sheet
MA130	Mounting adaptor	: See below
PA15x	Probe mounting adaptors	: Refer to corresponding data sheets
SG1xx	Cable feedthroughs	: Refer to corresponding data sheets

ACCESSORIES (continued)

MA130 DIN-rail mounting adaptor

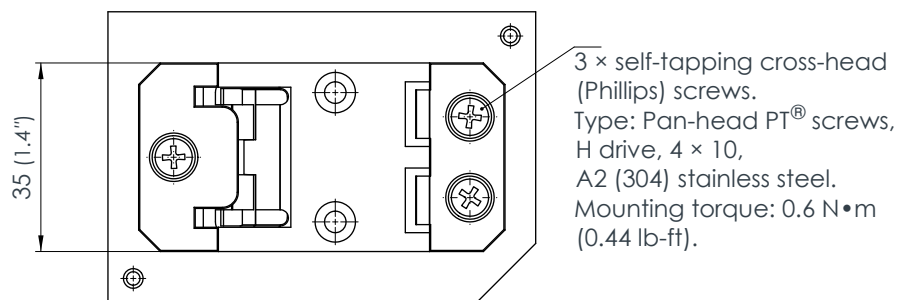
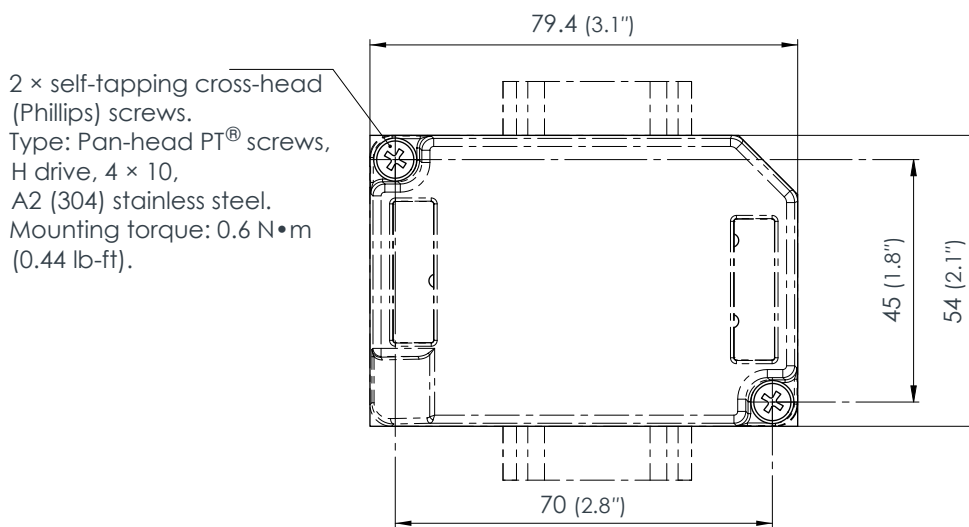
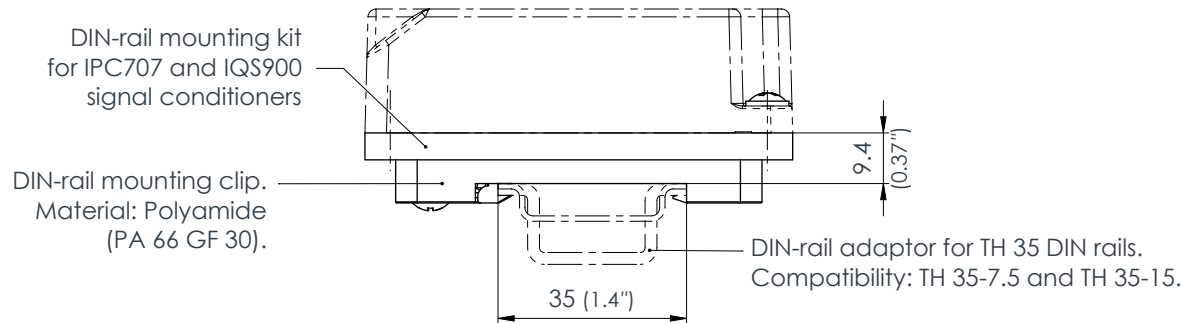

Note: All dimensions in mm (in) unless otherwise stated.

Ordering number (PNR): 809-130-000-021

RELATED PRODUCTS

TQ401, EA401 and IQS450	Proximity measurement system (2 mm measurement range)	: Refer to corresponding data sheet
TQ403, EA403 and IQS450	Proximity measurement system (12 mm measurement range)	: Refer to corresponding data sheet
TQ422/TQ432, EA402 and IQS450	Proximity measurement system (2 or 4 mm measurement range, high-pressure applications)	: Refer to corresponding data sheet
TQ423, EA403 and IQS450	Proximity measurement system (12 mm measurement range, high-pressure applications)	: Refer to corresponding data sheet
TQ442, EA402 and IQS450	Proximity measurement system (2 or 4 mm measurement range, right-angle (90°) mount)	: Refer to corresponding data sheet
PA150	Probe mounting adaptor with proximity measurement system	: Refer to corresponding data sheet
TQ902/TQ912, EA902 and IQS900	Proximity measurement chain (2 or 4 mm measurement range)	: Refer to corresponding data sheet

Meggitt (Meggitt PLC) is a leading international engineering company, headquartered in England, that designs and delivers high-performance components and subsystems for aerospace, defence and selected energy markets. Meggitt comprises four customer-aligned divisions: Airframe Systems, Engine Systems, Energy & Equipment and Services & Support.

The Energy & Equipment division includes the Energy Sensing and Controls product group that specialises in sensing and monitoring solutions for a broad range of energy infrastructure, and control valves for industrial gas turbines, primarily for the Power Generation, Oil & Gas and Services markets. Energy & Equipment is headquartered in Switzerland (Meggitt SA) and incorporates the vibro-meter® product line, which has over 65 years of sensor and systems expertise and is trusted by original equipment manufacturers (OEMs) globally.



All information in this document, such as descriptions, specifications, drawings, recommendations and other statements, is believed to be reliable and is stated in good faith as being approximately correct, but is not binding on Meggitt (Meggitt SA) unless expressly agreed in writing. Before acquiring and/or using this product, you must evaluate it and determine if it is suitable for your intended application. You should also check our website at www.meggittsensing.com/energy for any updates to data sheets, certificates, product drawings, user manuals, service bulletins and/or other instructions affecting the product.

Unless otherwise expressly agreed in writing with Meggitt SA, you assume all risks and liability associated with use of the product. Any recommendations and advice given without charge, whilst given in good faith, are not binding on Meggitt SA. Meggitt (Meggitt SA) takes no responsibility for any statements related to the product which are not contained in a current Meggitt SA publication, nor for any statements contained in extracts, summaries, translations or any other documents not authored and produced by Meggitt SA.

The certifications and warranties applicable to the products supplied by Meggitt SA are valid only for new products purchased directly from Meggitt SA or from an authorised distributor of Meggitt SA.

In this publication, a dot (.) is used as the decimal separator and thousands are separated by thin spaces. Example: 12345.67890.

Copyright© 2021 Meggitt SA. All rights reserved. The information contained in this document is subject to change without prior notice.

Sales offices

Meggitt has offices in more than 30 countries. For a complete list, please visit our website.

Local representative

Head office



Meggitt SA
Route de Moncor 4
Case postale
1701 Fribourg
Switzerland

Tel: +41 26 407 11 11
Fax: +41 26 407 13 01

energy@ch.meggitt.com

www.meggittsensing.com/energy
www.meggitt.com

DATA SHEET