

## DATA SHEET

# vibro-meter®

## CE281 piezoelectric accelerometer



### KEY FEATURES AND BENEFITS

- From the vibro-meter® product line
- Sensitivity: 10 µA/g
- Frequency response: 3 to 7000 Hz
- Temperature range: -55 to 260°C (sensor) and -40 to 125°C (electronics)
- Long-distance signal transmission
- Integrally attached electronics
- Integral case insulation
- Available in standard versions and Ex versions certified for use in potentially explosive atmospheres

### APPLICATIONS

- Vibration monitoring in harsh industrial environments and/or hazardous areas

### DESCRIPTION

The CE281 piezoelectric accelerometer from Meggitt's vibro-meter® product line is a vibration sensor designed for the monitoring and protection of machinery in harsh industrial environments and/or hazardous areas.

The CE281 sensor features a centre-mounted symmetrical shear-mode measuring element using polycrystalline material. The sensor uses integrally attached electronics to provide the required signal processing, eliminating the need for an external signal conditioner (charge amplifier). The attached electronics also performs charge-to-current conversion in order to provide a current-modulated output signal that is suitable for transmission over long distances.

The sensor head is connected to the attached electronics by an integral cable (low-noise, shielded) in a hermetically sealed link, protected by a flexible, leak-tight protection tube (stainless-steel hose). More specifically, the sensor head, protection tube and electronics housing are hermetically welded to one another, resulting in a system that is fully protected against cooling fluids, lubricants, water, steam and other potential contaminants.



Information contained in this document may be subject to export control regulations of the European Union, USA or other countries. Each recipient of this document is responsible for ensuring that transfer or use of any information contained in this document complies with all relevant export control regulations. ECN N/A.

## DESCRIPTION (continued)

The CE281 sensor and electronics are insulated from their housings (integral case insulation) and have a sensitivity of 10  $\mu\text{A/g}$ . The CE281 is available in different versions for different industrial environments: standard versions for use in standard (non-hazardous) areas and Ex versions for installation in hazardous areas (see **Ordering information on page 8**).

The CE281 piezoelectric accelerometer is an extremely reliable device that is suitable for the long-term monitoring of vibration in many industrial applications.

For specific applications, contact your local Meggitt representative.

## SPECIFICATIONS

### General

Input power supply requirements	: 15 to 28 $V_{\text{DC}}$ , with a bias (standby) current of 5 to 8 mA
Signal transmission	: Current-modulated output (2-wire system)
Signal processing	
• Internal	: Integrally attached electronics (charge-to-current conversion)
• External	: Galvanic separation unit and/or monitoring system electronics

### Operating

(At 23°C  $\pm$ 5°C, 73°F  $\pm$ 9°F)

Sensitivity	: 10 $\mu\text{A/g}$ $\pm$ 5%
Dynamic measurement range (sensor head only)	: 0.0001 to 200 g PEAK
Overload capacity (spikes) (sensor head only)	: Up to 2000 g PEAK
Linearity	: $\pm$ 1% over dynamic measurement range
Transverse sensitivity	: <3% (measured at 15 Hz with 5 g)
Resonant frequency (mounted)	: 25 kHz typ.
Frequency response	: < $\pm$ 5% between 3 and 7000 Hz

### Environmental

Temperature range	
• Sensor head	: -55 to 260°C (-67 to 500°F) continuous operation. -70 to 290°C (-94 to 554°F) short-term survival (15 minutes max.).
• Attached electronics	: -40 to 125°C (-40 to 257°F) continuous operation. -55 to 150°C (-67 to 302°F) short-term survival (15 minutes max.).
Temperature sensitivity error with respect to 23°C (73°F) (sensor head only)	: $\pm$ 5% between -20 and 260°C (-4 to 500°F). -14% to +5% between -55 and 260°C (-67 to 500°F).
Shock acceleration	
• Sensor head	: 2000 g PEAK (half-sine wave, 1 ms duration)
• Attached electronics	: 500 g PEAK (half-sine wave, 1 ms duration)

## SPECIFICATIONS *(continued)*

---

### Corrosion, humidity

- Sensor head : INCONEL<sup>®</sup> alloy 600, hermetically welded
- Flexible stainless-steel hose : Stainless steel (1.4541), hermetically welded  
(protection tube)
- Attached electronics : Stainless steel (1.4441), hermetically welded

*Note: The sensor head, protection tube and electronics housing are hermetically welded to one another to create a leak-tight assembly that is impervious to 100% relative humidity, water, steam or oil, sea-salt atmospheres and other potential contaminants such as dust, fungus and sand.*

Base strain sensitivity : 0.0025 g/ $\mu\epsilon$  typ.

## SPECIFICATIONS *(continued)*

### Potentially explosive atmospheres

Available in Ex approved versions for use in hazardous areas

Type of protection Ex ia: intrinsic safety		
Europe	EC type examination certificate	 II 1 G (Zones 0, 1, 2) Ex ia IIC T6...T2 Ga KEMA 04 ATEX 1055
International	IECEX certificate of conformity	Ex ia IIC T6...T2 Ga IECEX DEK 15.0029
North America	cCSAus certificate of compliance	Class I, Division 1, Groups A, B, C, D Ex ia IIC T6...T2 Ga Class I, Zone 0 AEx ia IIC T6...T2 Ga cCSAus 1514310
South Korea	KGS certificate of conformity	Ex ia IIC T6...T2 KGS 17-GA4BO-0322X
Russian Federation	EAЭC RU certificate of conformity*	0Ex ia IIC T6...T2 Ga X EAЭC RU C-CH.AΔ07.B.03042/21

Type of protection Ex nA: non-sparking		
Europe	Voluntary type examination certificate	 II 3 G (Zone 2) Ex nA IIC T6...T2 Gc LCIE 09 ATEX 1047 X
International	IECEX certificate of conformity*	Ex nA IIC T6...T2 Gc IECEX LCI 10.0021X
North America	cCSAus certificate of compliance	Class I, Division 2, Groups A, B, C, D Ex nA IIC T6...T2 Gc Class I, Zone 2 AEx nA IIC T6...T2 Gc cCSAus 1514310
Russian Federation	EAЭC RU certificate of conformity*	2Ex nA IIC T6...T2 Gc EAЭC RU C-CH.AΔ07.B.03042/21

\*Not engraved/marked on all products.

 For specific parameters of the mode of protection concerned and special conditions for safe use, refer to the Ex certificates that are available from Meggitt SA.

 For the most recent information on the Ex certifications that are applicable to this product, refer to the Ex product register (PL-1511) document that is available from Meggitt SA.

## SPECIFICATIONS *(continued)*

---

### Approvals

Conformity	: European Union (EU) declaration of conformity (CE marking). EAC marking, Eurasian Customs Union (EACU) certificate/ declaration of conformity.
Electromagnetic compatibility	: EN 61000-6-2:2005. EN 61000-6-4:2007 + A1:2011.
Electrical safety	: EN 61010-1:2010
Environmental management	: RoHS compliant (2011/65/EU)
Hazardous areas	: Ex approved versions (see <b>Potentially explosive atmospheres on page 4</b> )
Russian federal agency for technical regulation and metrology (Rosstandart)	: Pattern approval certificate OC.C.28.004.A N° 59463

### Calibration

Dynamic calibration at factory at 120 Hz and 5 g PEAK (23°C, 73°F). No subsequent calibration necessary.

### Mechanical

Dimensions	: See <b>Mechanical drawings on page 6</b>
Connection	
• Bayonet connector	: MS3112E8-3P (stainless steel). Mates with a CG134 bayonet connector (MS3112E08-3S).
• Threaded connector	: EN2997Y10803MN (stainless steel). Mates with a CG134 threaded connector (MIL-C-83723).
Weight	
• Sensor head	: 70 g (0.15 lb) approx.
• Cable/flexible stainless-steel hose (protection tube)	: 135 g/m (0.091 lb/ft) approx.
• Attached electronics	: 200 g (0.44 lb) approx.
Mounting	
• Sensor head	: Three M4 × 16 Allen bolts (hexagonal socket head) with three M4 spring-lock washers. Mounting torque of 4.5 N•m (3.3 lb-ft).
• Attached electronics	: Four M6 × 35 Allen bolts (hexagonal socket head) with four M6 spring-lock washers. Mounting torque of 15 N•m (11.1 lb-ft).
	Note: See the Mounting adaptors in <b>Accessories on page 8</b> and refer also to the <i>Vibration measurement chains using CExxx or PVxxx sensors installation manual</i> .

MECHANICAL DRAWINGS

CE281 with bayonet connector

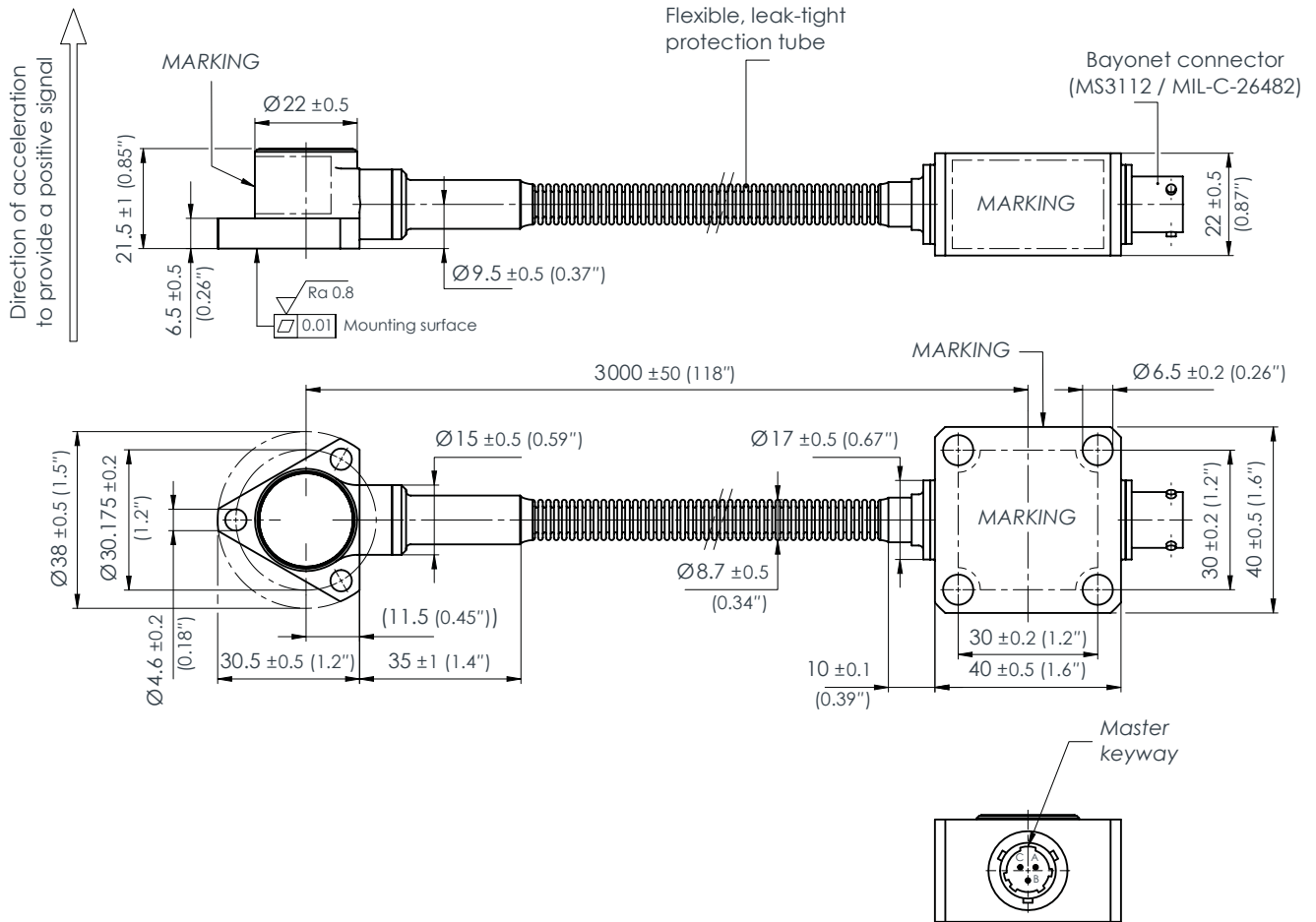

Wiring diagram

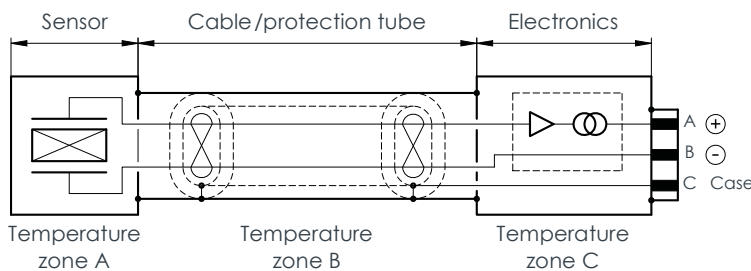

Temperature zones

- Zone A: -55 to 260°C (-67 to 500°F)
- Zone B: -55 to 260°C (-67 to 500°F)
- Zone C: -40 to 125°C (-40 to 257°F)

Notes

All dimensions in mm (in) unless otherwise stated.

The CE281 with the bayonet connector and the CE281 with the threaded connector are identical except for the type of connector fitted to the integrally attached electronics housing.

Pins B and C of the bayonet connector must be connected together externally.

MECHANICAL DRAWINGS (continued)

CE281 with threaded connector

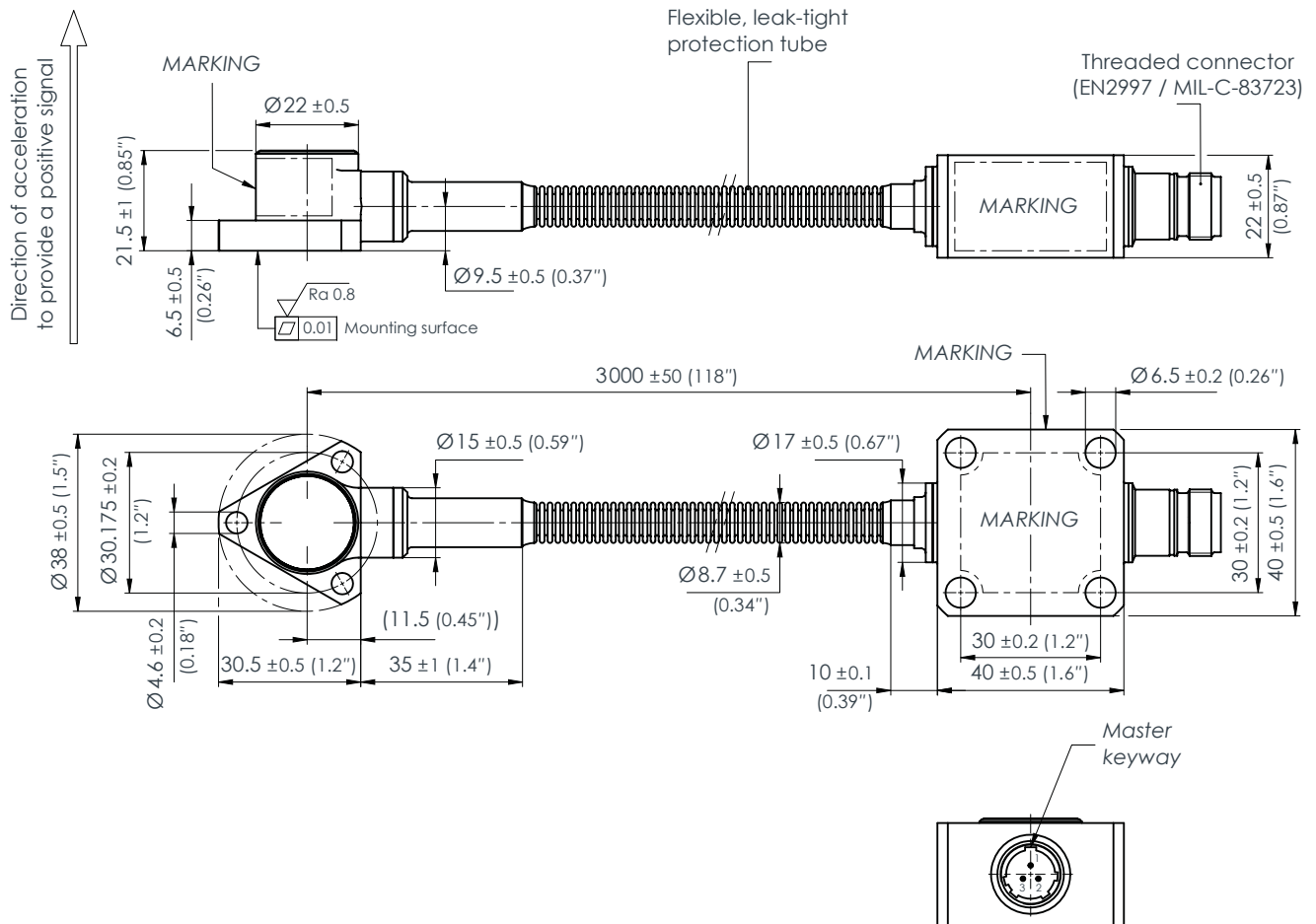

Wiring diagram

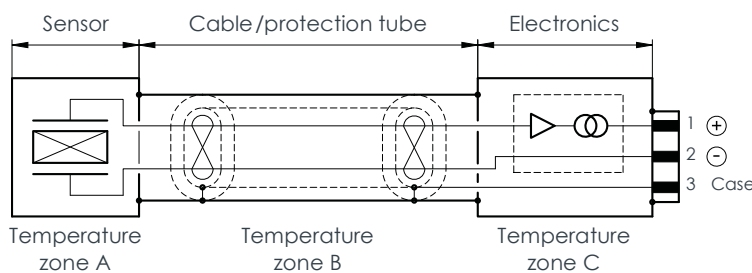

Temperature zones

- Zone A: -55 to 260°C (-67 to 500°F)
- Zone B: -55 to 260°C (-67 to 500°F)
- Zone C: -40 to 125°C (-40 to 257°F)

Notes

All dimensions in mm (in) unless otherwise stated.

The CE281 with the bayonet connector and the CE281 with the threaded connector are identical except for the type of connector fitted to the integrally attached electronics housing.

Pins 2 and 3 of the bayonet connector must be connected together externally.

## ORDERING INFORMATION

---

To order please specify

Type	Designation	Ordering number (PNR)
CE281	Different versions of the piezoelectric accelerometer: – Standard version with bayonet connector – Ex version with bayonet connector – Ex version with threaded connector	444-281-000-013 444-281-000-113 444-281-000-213

## ACCESSORIES

---

### Mounting adaptors

MA133	Thermal insulation kit	Refer to the 809-133-000V011 product drawing
TA102	Mounting adaptor	Refer to the 444-310-401D101 product drawing
TA104	Mounting adaptor	Refer to the 144-136-301D101 product drawing

### Cable assemblies

EC175	Cable assemblies	Cable assemblies with bayonet or threaded connector and flying leads. Refer to the 922-175-000V104 and 922-175-000V154 product drawings
EE139	Cable assembly	Cable assemblies with bayonet connector and flying leads. Refer to the 924-139-000V002 product drawing
EE143	Cable assembly	Cable assemblies with threaded connector and flying leads. Refer to the 924-143-000V002 product drawing

### Connectors

CG134	3-pin connector	Refer to the 812-134-000D031 product drawing for the threaded connector (MIL-C-83723, stainless steel) to be used with K209 cable – suitable for use in non-explosive atmospheres (ordinary applications) Refer to the 812-134-000D041 product drawing for the threaded connector (MIL-C-83723, stainless steel) to be used with K210 cable – suitable for use in potentially explosive atmospheres (hazardous areas) Refer to the 812-134-000D051 product drawing for the bayonet connector (MS3112E08-3S, aluminium) to be used with K209 or K210 cable (non-explosive or potentially explosive atmospheres)
-------	-----------------	--

### Junction boxes

JB105	Refer to the data sheet
JB116	Refer to the data sheet



## ACCESSORIES *(continued)*

---

### Transmission cables

K2xx Refer to the data sheets

### Galvanic separation units

GS1127 Refer to the data sheet

Meggitt (Meggitt PLC) is a leading international engineering company, headquartered in England, that designs and delivers high-performance components and subsystems for aerospace, defence and selected energy markets. Meggitt comprises four customer-aligned divisions: Airframe Systems, Engine Systems, Energy & Equipment and Services & Support.

The Energy & Equipment division includes the Energy Sensing and Controls product group that specialises in sensing and monitoring solutions for a broad range of energy infrastructure, and control valves for industrial gas turbines, primarily for the Power Generation, Oil & Gas and Services markets. Energy & Equipment is headquartered in Switzerland (Meggitt SA) and incorporates the vibro-meter<sup>®</sup> product line, which has over 65 years of sensor and systems expertise and is trusted by original equipment manufacturers (OEMs) globally.



All information in this document, such as descriptions, specifications, drawings, recommendations and other statements, is believed to be reliable and is stated in good faith as being approximately correct, but is not binding on Meggitt (Meggitt SA) unless expressly agreed in writing. Before acquiring and/or using this product, you must evaluate it and determine if it is suitable for your intended application. You should also check our website at [www.meggittsensing.com/energy](http://www.meggittsensing.com/energy) for any updates to data sheets, certificates, product drawings, user manuals, service bulletins and/or other instructions affecting the product.

Unless otherwise expressly agreed in writing with Meggitt SA, you assume all risks and liability associated with use of the product. Any recommendations and advice given without charge, whilst given in good faith, are not binding on Meggitt SA. Meggitt (Meggitt SA) takes no responsibility for any statements related to the product which are not contained in a current Meggitt SA publication, nor for any statements contained in extracts, summaries, translations or any other documents not authored and produced by Meggitt SA.

The certifications and warranties applicable to the products supplied by Meggitt SA are valid only for new products purchased directly from Meggitt SA or from an authorised distributor of Meggitt SA.

In this publication, a dot (.) is used as the decimal separator and thousands are separated by thin spaces. Example: 12345.67890.

Copyright© 2022 Meggitt SA. All rights reserved. The information contained in this document is subject to change without prior notice.

### Sales offices

Meggitt has offices in more than 30 countries. For a complete list, please visit our website.

### Local representative

### Head office

Meggitt SA  
Route de Moncor 4  
Case postale  
1701 Fribourg  
Switzerland

Tel: +41 26 407 11 11

Fax: +41 26 407 13 01

[energy@ch.meggitt.com](mailto:energy@ch.meggitt.com)

[www.meggittsensing.com/energy](http://www.meggittsensing.com/energy)

[www.meggitt.com](http://www.meggitt.com)

