

**BEST OF
CLASS**



The Jewell LCA Series Accelerometer is a general-purpose $\pm 0.5G$ to $\pm 5G$ device designed for industrial, commercial and aerospace sensing requirements.

LCA-100 Series Accelerometer Specifications

Performance

Input Range, g (Note 1)	± 0.50	± 2.0	± 5.0
Full Range Output (FRO), volts $\pm 0.5\%$	± 5.0	± 5.0	± 5.0
Nonlinearity, % FRO max (Note 2)	0.05%	0.05%	0.05%
Scale Factor, volts/g nominal	10.0	2.50	1.00
Scale Factor Temp. Sens, PPM/ $^{\circ}C$ max	180	180	180
Bias, g max	0.010	0.010	0.010
Bias Temperature Sens, micro g/ $^{\circ}C$ max	100	100	100
Natural Frequency, Hz min (Note 3)	60	60	60
Bandwidth (-3 dB), Hz min	60	60	60
Input Axis Misalignment, $^{\circ}$ max	1.0	1.0	1.0
Resolution and Threshold, micro g max	100	100	100

Electrical

Input Voltage, VDC	± 12 to ± 18
Input Current, mA nominal	± 25
Output Impedance, ohms nominal	100
Noise, Vrms max	0.005

Environmental

Operating Temp Range	-55 to $+85^{\circ}C$
Survival Temp Range	-60 to $+90^{\circ}C$
Shock	100g, 11 msec, $\frac{1}{2}$ sine
Seal	Epoxy

NOTE 1: Full Range is defined as "from negative to positive full input acceleration."

NOTE 2: Referenced to a best-fit straight line independent of misalignment.

NOTE 3: Output phase angle = -90° .

Applications

- Aircraft Flight Controls
- Fatigue Monitoring
- Performance Testing

LCA-100 Series Accelerometer

Block Diagram

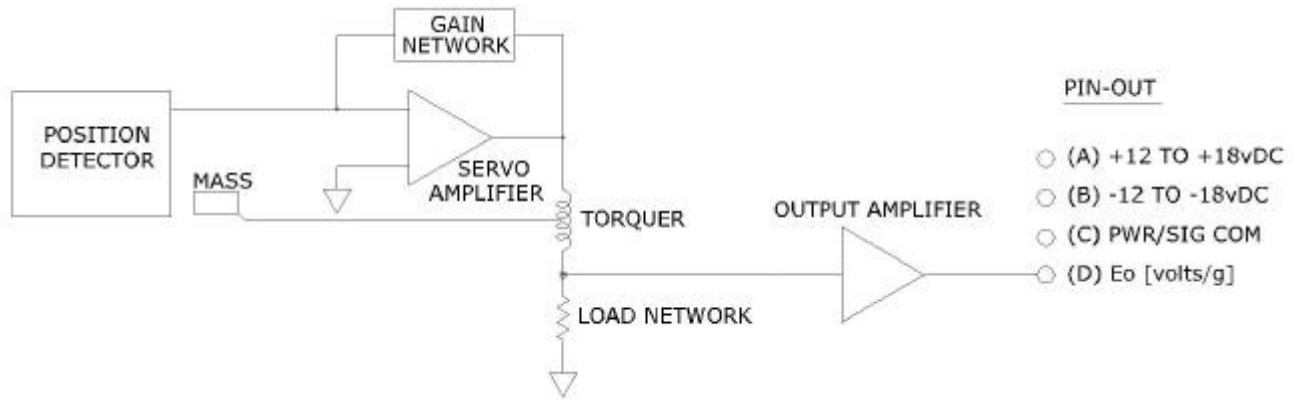

Outline Diagram

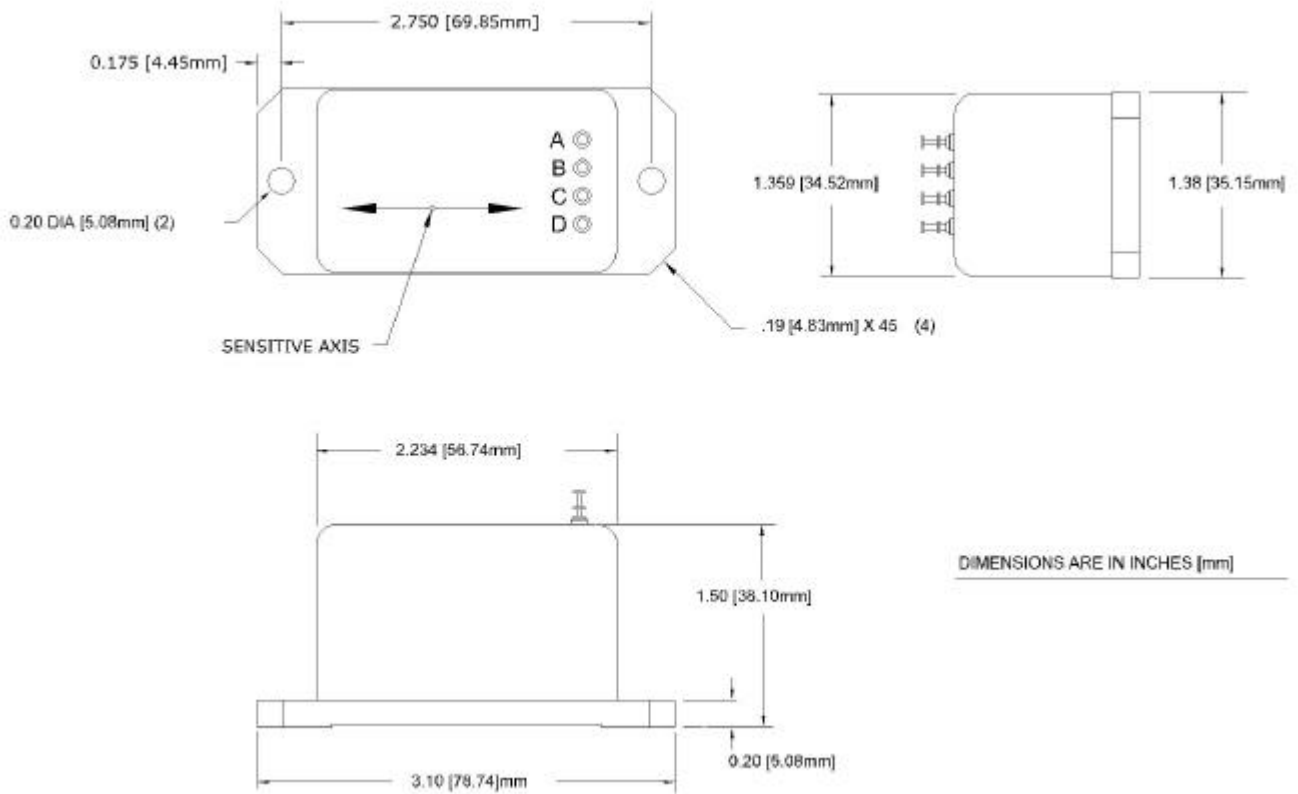

sales@jewellinstruments.com www.jewellinstruments.com 800 227-5955
850 Perimeter Road Manchester, NH 03103 USA 603-669-6400