









# More Precision.

indu**SENSOR** // Linear inductive displacement sensors





-  **Compact and robust aluminum housing**
-  **High resolution and linearity**
-  **Ideal for serial applications in machine building and automation**
-  **User-friendly parameter setting via buttons or software**
-  **Models with plug and cable bushings**
-  **Robust design IP67**
- INTER FACE** **Analog (U/I) / RS485/ Ethernet / EtherCAT / PROFINET / EtherNet/IP**

The MSC7401 / MSC7802 controllers are designed to be operated with measuring gauges and displacement sensors of the DTA (LVDT) and LDR (half-bridge sensors) series. Due to their robust aluminum housing protected to IP67, the controllers are predestined for industrial measurement tasks.

A large variety of compatible, inductive displacement sensors and gauges from Micro-Epsilon combined with an optimized price/performance ratio opens up numerous fields of applications in automation technology and machine building. The controller is easily set up using buttons or software. Besides the basic settings, adjusting the measuring systems is also possible. Users can either choose the symmetrical adjustment around the zero point in order to make optimum use of the specific advantages of differential sensors, or teach in two almost arbitrary points within the measuring range. If desired, these settings can be made at the factory and documented with a manufacturer test certificate.

**Example configuration**  
MSC7401 with DTA-5G8-3-CA gauge:



Technical Data	Channel with DTA-5G8-3-CA
Measuring range	±5 mm
Linearity	30 µm
Resolution	~1.2 µm
Output	Analog and RS485



Model		MSC7401	MSC7802
Resolution <sup>1)</sup>	DTA series	13 bits (0.012 % FSO) at 50 Hz 12 bits (0.024 % FSO) at 300 Hz	
	LDR series	12 bits (0.024 % FSO) at 50 Hz 11 bits (0.048 % FSO) at 300 Hz	
Frequency response (-3dB)		300 Hz (adjustable only via software)	
Linearity		≤ ±0.02% FSO	
Temperature stability	DTA series	≤ 100 ppm FSO/K	
	LDR series	≤ 125 ppm FSO/K	
Supply voltage		14 ... 30 VDC (5 ... 30 VDC <sup>2)</sup> )	
Max. current consumption		40 mA	80 mA
Input impedance <sup>3)</sup>		> 100 kOhm	
Digital interface		RS485 / PROFINET <sup>4)</sup> / EtherNet/IP <sup>4)</sup> / Ethernet <sup>4)</sup> / EtherCAT <sup>4)</sup>	RS485 / PROFINET <sup>4)</sup> / EtherNet/IP <sup>4)</sup>
Analog output <sup>4)</sup>		(0)2 ... 10 V; 0.5 ... 4.5 V; 0 ... 5 V (Ra > 1 kOhm) or 0(4) ... 20 mA (load < 500 ohm)	
Connection		Sensor: screw terminal AWG 16 up to AWG 24; with ferrule up to AWG 28 or 5-pin M9 connector (cable see accessories) Supply/signal: screw terminal AWG 16 up to AWG 24; with ferrule up to AWG 28 or 5-pin M12 connector (cable see accessories)	
Mounting		2x mounting holes for M4	
Temperature range	Storage	-40 ... +85 °C	
	Operation	-40 ... +85 °C	
Shock (DIN EN 60068-2-27)		40 g / 6 ms in 3 axes, 2 directions and 1000 shocks each 100 g / 5 ms in 3 axes, 2 directions and 9 shocks each	
Vibration (DIN EN 60068-2-6)		± 1.5 mm / 5 ... 57 Hz in 3 axes, 10 cycles each ± 20 g / 57 ... 500 Hz in 3 axes, 10 cycles each	
Protection class (DIN EN 60529)		IP67 (plugged)	
Material		Aluminum die casting	
Weight		approx. 200 g	approx. 280 g
Compatibility		full-bridge sensor/LVDT (DTA series) and half-bridge sensor (LDR series)	
No. of measurement channels		1	2

FSO = Full Scale Output

<sup>1)</sup> Noise: AC RMS measurement via RC low-pass filter of the 1st order with  $f_c = 5$  kHz

<sup>2)</sup> With technical restrictions of the output signal (load and signal span)

<sup>3)</sup> Sensor side

<sup>4)</sup> Connection via interface module (see accessories)

<sup>5)</sup>  $0\text{ V} \pm < 30\text{ mV}$ ,  $0\text{ mA} \pm < 35\text{ }\mu\text{A}$ ; with controllers including a current output, the output signal is limited to approx. 21 mA

MSC7401

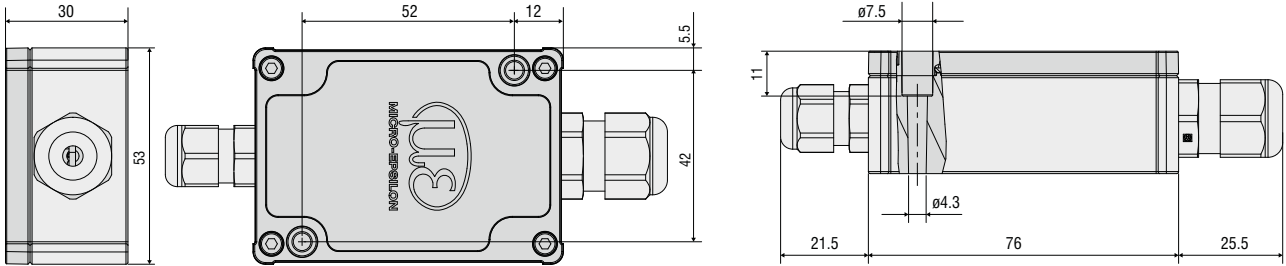

MSC7401(010)

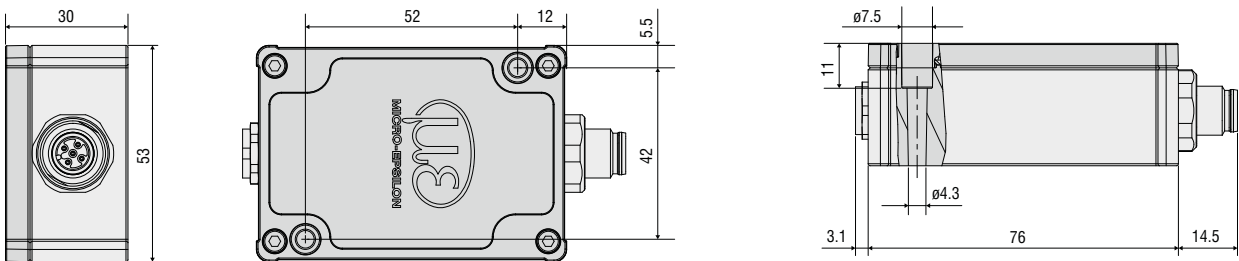

MSC7401(020)

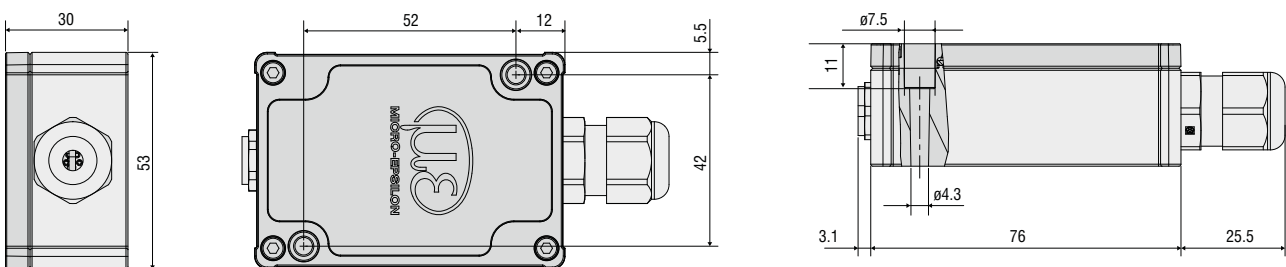

MSC7401(030)

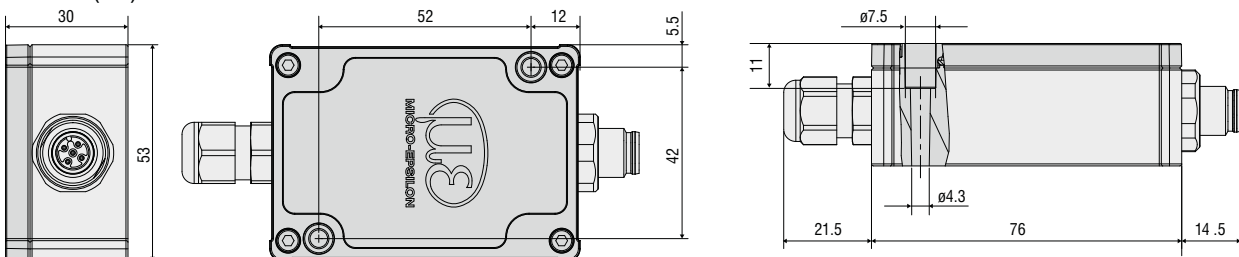

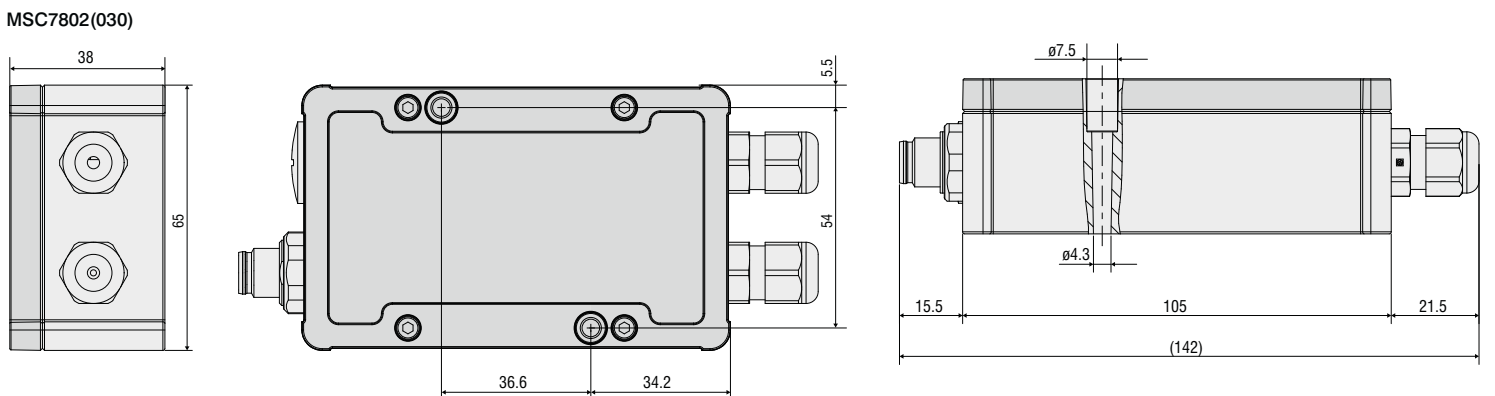
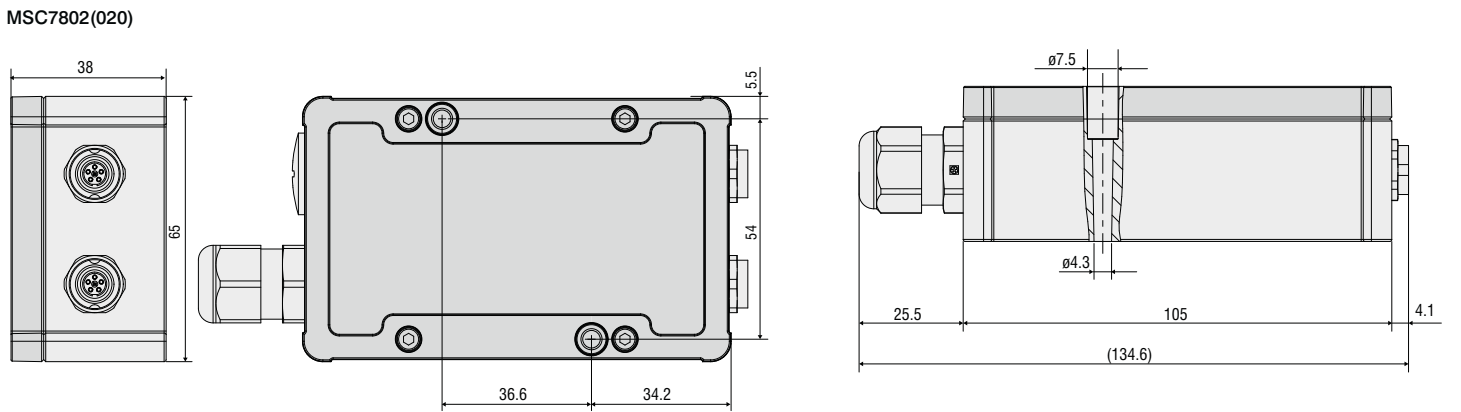
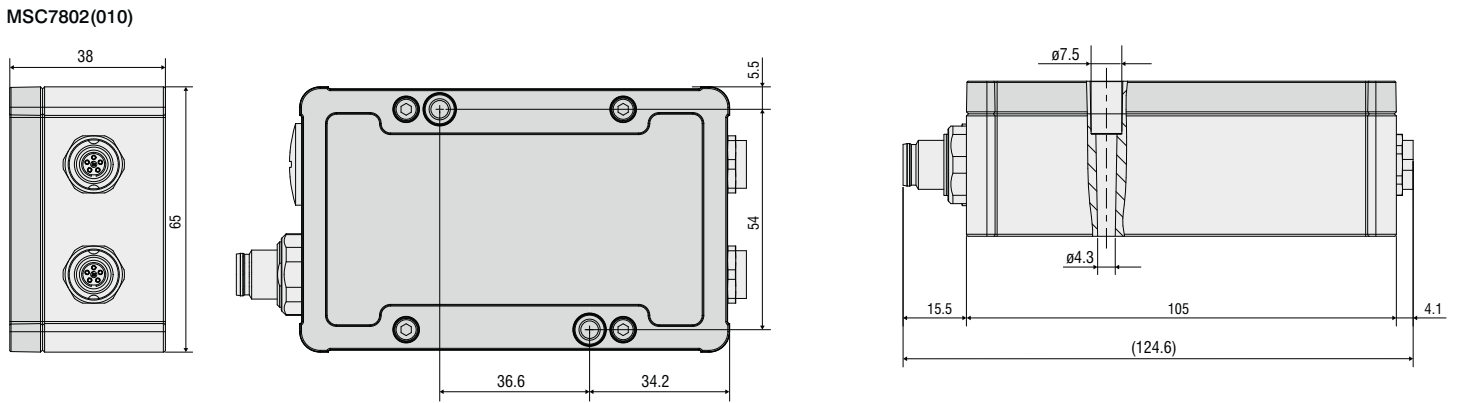
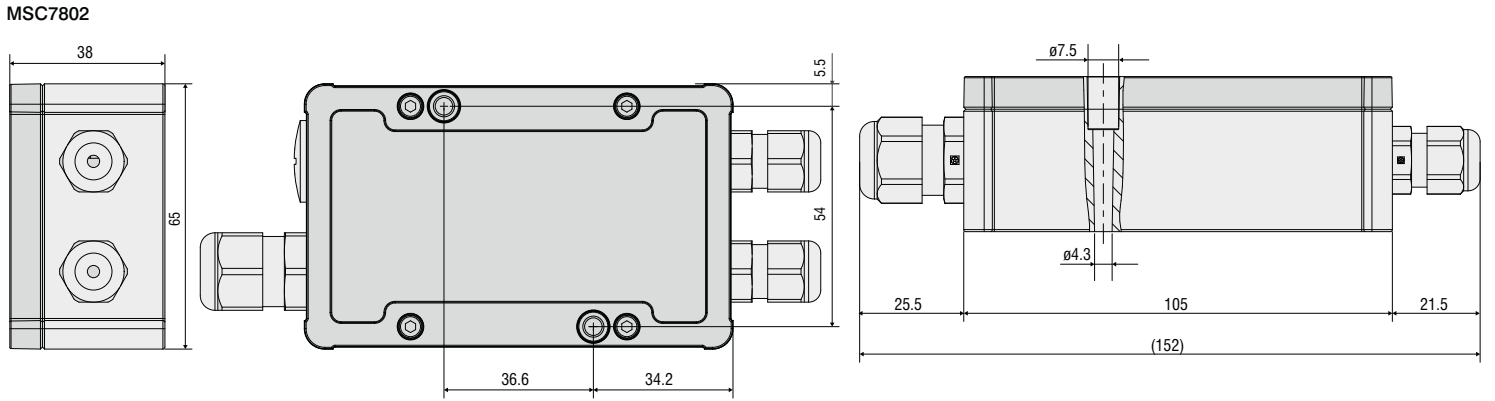

Dimensions in mm, not to scale

## Accessories for MSC7401 / MSC7602 / MSC7802

### Connection cables

PC7400-6/4	Supply and output cable, 6 m
PC5/5-IWT	Supply and output cable, 5 m (only MSC7401 / MSC7802)
IF7001	Single-channel USB/RS485 converter for MSC7xxx
MSC7602 connector kit	



MSC7602 connector kit

### Service

Connection, adjustment and calibration including manufacturer certificate

### Interface modules

IF2030/ENETIP	DIN rail interface module for Ethernet/IP (multi-channel)
IF2030/PNET	DIN rail interface module for ProfiNet (multi-channel)
IF1032/ETH	Interface module for Ethernet/EtherCAT (single channel) (only MSC7401 / MSC7802)

### Power supply units

PS2401/100-240/24V/1A	Universal power supply unit with open ends
-----------------------	--

## Connection options MSC7401

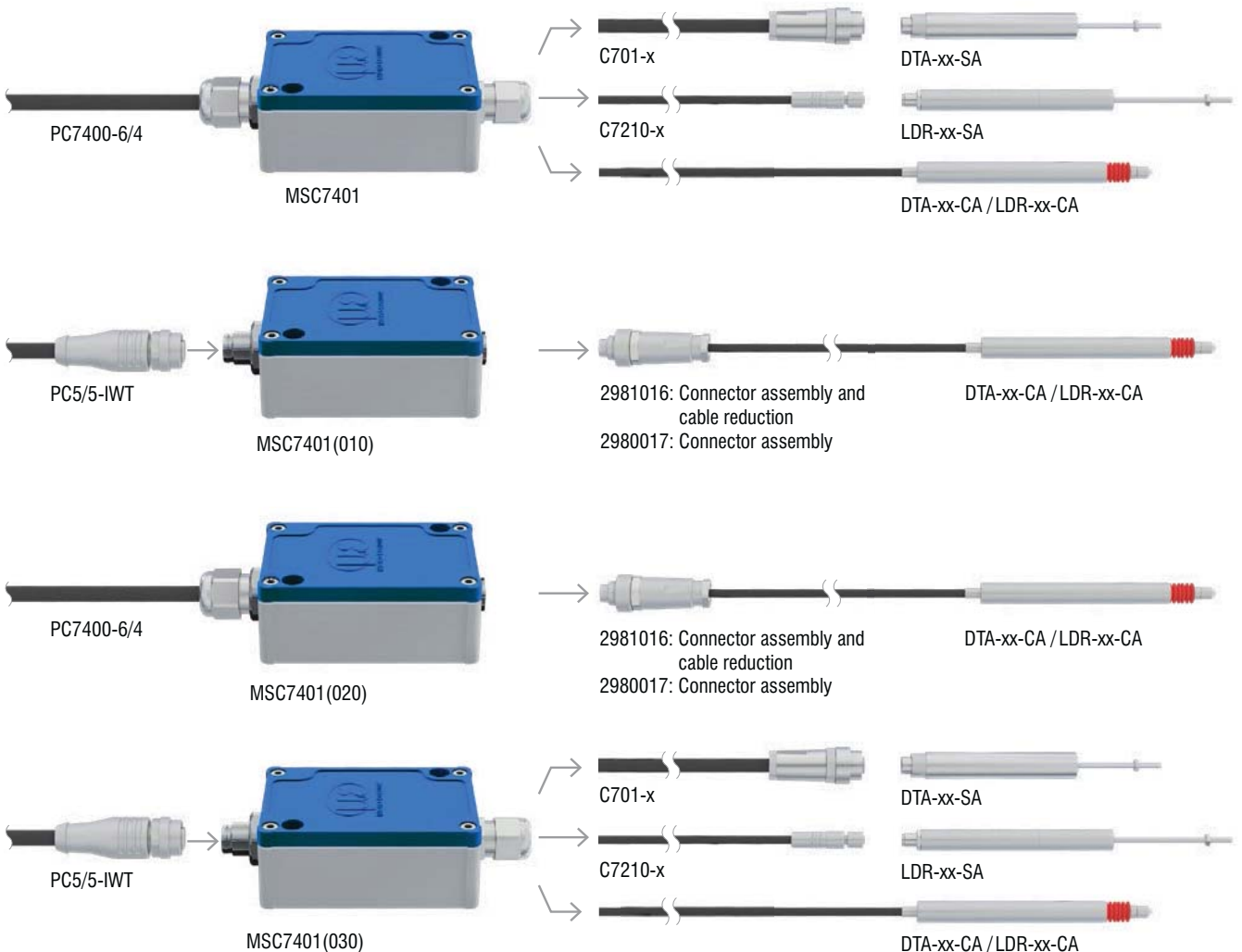

## Sensors and Systems from Micro-Epsilon



Sensors and systems for displacement, distance and position



Sensors and measurement devices for non-contact temperature measurement



Measuring and inspection systems for metal strips, plastics and rubber



Optical micrometers and fiber optics, measuring and test amplifiers



Color recognition sensors, LED analyzers and inline color spectrometers



3D measurement technology for dimensional testing and surface inspection

三協インタナショナル株式会社  
 本社 〒103-0003 東京都中央区日本橋横山町9-14  
 TEL(03)3662-8100 FAX(03)3662-8050  
 大阪営業所 〒531-0072 大阪市北区豊崎2-10-17  
 TEL(06)6372-5843 FAX(06)6371-7180  
 名古屋営業所 〒465-0093 名古屋市名東区一社1-148  
 TEL(052)709-1781 FAX(052)709-1782



**MICRO-EPSILON**

MICRO-EPSILON Headquarters  
 Koenigbacher Str. 15 · 94496 Ortenburg / Germany  
 Tel. +49 (0) 8542 / 168-0 · Fax +49 (0) 8542 / 168-90  
 info@micro-epsilon.com · [www.micro-epsilon.com](http://www.micro-epsilon.com)

三協インタナショナル株式会社 03-3662-8100