



XS-D SERIES

High stroke-to-length ratio LVDT

SPECIFICATIONS

- Excellent stroke-to-length ratio
- Lower weights than other standard LVDTs with comparable displacement ranges
- Stroke ranges from ± 1 to ± 10 inches
- Shock and vibration tolerant
- Stainless steel housing
- Magnetically shielded
- Imperial or metric threaded core

The **XS-D Series** LVDTs are specifically designed for measuring relatively large displacements where installation space is limited. The XS-D Series have a substantially greater displacement range than other standard LVDTs, but without the accompanying increase in body length and weight. Using special coil winding techniques, the XS-D permits linear range measurements of up to 80% of the housing length.

Compact, shock and vibration tolerant, and featuring infinite resolution and repeatability, the XS-D Series are the perfect choice for servo mechanisms, linear potentiometer replacement, or wherever precise displacement measurements are required in space restrictive applications. All models are supplied with a calibration certificate, and are available with either an imperial or metric threaded core. The XS-D Series are compatible with all Measurement Specialties LVDT signal conditioners, controllers and readouts.

Like in most of our LVDTs, the XS-D windings are vacuum impregnated with a specially formulated, high temperature, flexible resin, and the coil assembly is potted inside its housing with a two-component epoxy. This provides excellent protection against hostile environments such as high humidity, vibration and shock.

FEATURES

- Superior stroke-to-length ratio
- Stroke ranges from ± 1 to ± 10 inches
- Smooth transfer function
- AISI 400 Series stainless steel housing
- Calibration certificate supplied with all units

APPLICATIONS

- Servo mechanisms
- Hydraulic actuators
- Linear potentiometer replacement
- Space restrictive installations
- Weight sensitive applications

XS-D SERIES

High stroke-to-length ratio LVDT

PERFORMANCE SPECIFICATIONS

ELECTRICAL SPECIFICATIONS					
Parameter	XS-D 1002	XS-D 2002	XS-D 3002	XS-D 5002	XS-D 10002
Stroke range	±1 [±25.4]	±2 [±50.8]	±3 [±76.2]	±5 [±127]	±10 [±254]
Sensitivity V/V/inch [mV/V/mm]	0.28 [11.0]	0.16 [6.3]	0.12 [4.7]	0.13 [5.1]	0.05 [2.0]
Output at stroke ends (*)	280mV/V	320mV/V	360mV/V	650mV/V	500mV/V
Phase shift	+30°	+25°	+7°	+0.5°	-4°
Input impedance (PRIMARY)	175Ω	243Ω	266Ω	968Ω	628Ω
Output impedance (SECONDARY)	230Ω	103Ω	220Ω	532Ω	416Ω
Non-linearity	±2.0% of FR, maximum				
Input voltage	3 VRMS sine wave				
Test input frequency	2.5kHz				
Input frequency range	400Hz to 3kHz				
Null voltage	0.5% of FRO, maximum				

ENVIRONMENTAL SPECIFICATIONS & MATERIALS	
Operating temperature	-65°F to +300°F [-55°C to 150°C]
Shock survival	1,000 g (11ms half-sine)
Vibration tolerance	20 g up to 2KHz
Housing material	AISI 410 Series stainless steel
Electrical connection	Six lead-wires, stranded 28 AWG, PTFE insulated, 1 foot [0.3m] long
IEC 60529 rating	IP61

Notes:*Dimensions are in inch [mm]**All values are nominal unless otherwise noted**Electrical specifications are for the test frequency indicated in the table**(*): Unit for output at stroke ends is millivolt per volt of excitation (input voltage)**FR: Full Range is the stroke range, end to end; FR=2xS for ±S stroke range**FRO (Full Range Output): Algebraic difference in outputs measured at the ends of the range*

XS-D SERIES

High stroke-to-length ratio LVDT

MECHANICAL SPECIFICATIONS

Parameter	XS-D 1002	XS-D 2002	XS-D 3002	XS-D 5002	XS-D 10002
Main body length "A"	2.57 [65.2]	5.76 [146.3]	7.50 [190.5]	12.52 [318.0]	25.06 [636.5]
Core length "B"	0.45 [11.4]	1.50 [38.1]	1.25 [31.8]	2.40 [61.0]	4.00 [101.6]
Bore diameter "D"	0.265 [6.73]	0.265 [6.73]	0.30 [7.62]	0.30 [7.62]	0.35 [8.89]
Body weight, oz [g]	2.3 [65]	4.1 [115]	4.9 [140]	7.6 [215]	16.6 [470]
Core weight, oz [g]	0.09 [2.5]	0.28 [8.0]	0.24 [6.8]	0.44 [12.5]	0.88 [25.0]

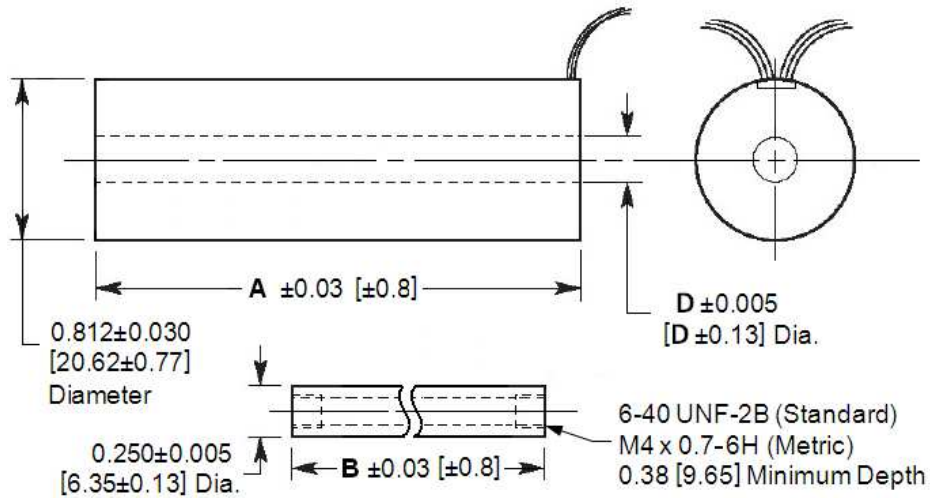

Dimensions are in inches [mm]

WIRING INFORMATION

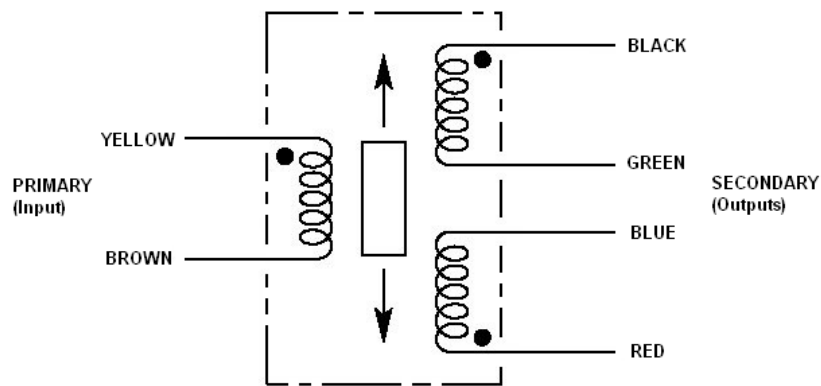

Connect Green to Blue for differential output

XS-D SERIES

High stroke-to-length ratio LVDT

ORDERING INFORMATION

Description	Model	Part Number
±1 inch LVDT	XS-D1002	02560567-000
±2 inch LVDT	XS-D2002	02560568-000
±3 inch LVDT	XS-D3002	02560569-000
±5 inch LVDT	XS-D5002	02560571-000
±10 inch LVDT	XS-D10002	02560572-000

OPTIONS

Description	Model	Part Number
Metric threaded core option (M4x0.7-6H threads)	All	XXXXXXXX-006

ACCESSORIES

Description	Part Number
Core connecting rod, 6 inches long, 6-40 threads	05282947-006
Core connecting rod, 12 inches long, 6-40 threads	05282947-012
Core connecting rod, 24 inches long, 6-40 threads	05282947-024
Core connecting rod, 36 inches long, 6-40 threads	05282947-036
Core connecting rod, 6 inches long, M4x0.7 metric threads	05282978-006
Core connecting rod, 12 inches long, M4x0.7 metric threads	05282978-012
Mounting block	04560952-000

NORTH AMERICA

Measurement Specialties, Inc.,
a TE Connectivity Company
1000 Lucas Way
Hampton, VA 23666
United States
Phone: +1-800-745-8008
Fax: +1-757-766-4297
Email: sales@meas-spec.com

EUROPE

MEAS Deutschland GmbH (Europe)
a TE Connectivity Company
Hauert 13
D-44227 Dortmund
Germany
Phone: +49-(0)231-9740-0
Fax: +49-(0)231-9740-20
Email: info.de@meas-spec.com

ASIA

Measurement Specialties (China), Ltd.,
a TE Connectivity Company
No. 26 Langshan Road
Shenzhen High-Tech Park (North)
Nanshan District, Shenzhen 518057
China
Phone: +86-755-33305088
Fax: +86-755-33305099
Email: info.cn@meas-spec.com

TE.com/sensorsolutions

Measurement Specialties, Inc., a TE Connectivity company.

Accustar, American Sensor Technologies, AST, ATEXIS, DEUTSCH, IdentiCal, TruBlue, KPSI, Krystal Bond, Microfused, UltraStable, Measurement Specialties, MEAS, Schaevitz, TE Connectivity, TE, and the TE connectivity (logo) are trademarks of the TE Connectivity Ltd. family of companies. Other logos, product and company names mentioned herein may be trademarks of their respective owners.

The information given herein, including drawings, illustrations and schematics which are intended for illustration purposes only, is believed to be reliable. However, TE Connectivity makes no warranties as to its accuracy or completeness and disclaims any liability in connection with its use. TE Connectivity's obligations shall only be as set forth in TE Connectivity's Standard Terms and Conditions of Sale for this product and in no case will TE Connectivity be liable for any incidental, indirect or consequential damages arising out of the sale, resale, use or misuse of the product. Users of TE Connectivity products should make their own evaluation to determine the suitability of each such product for the specific application.

© 2015 TE Connectivity Ltd. family of companies All Rights Reserved.