



More Precision.

wireSENSOR // Draw-wire displacement sensors





- Miniature design
- Optional IP67 (MPW)
- For fast movements and harsh application environments

MP / MPW models

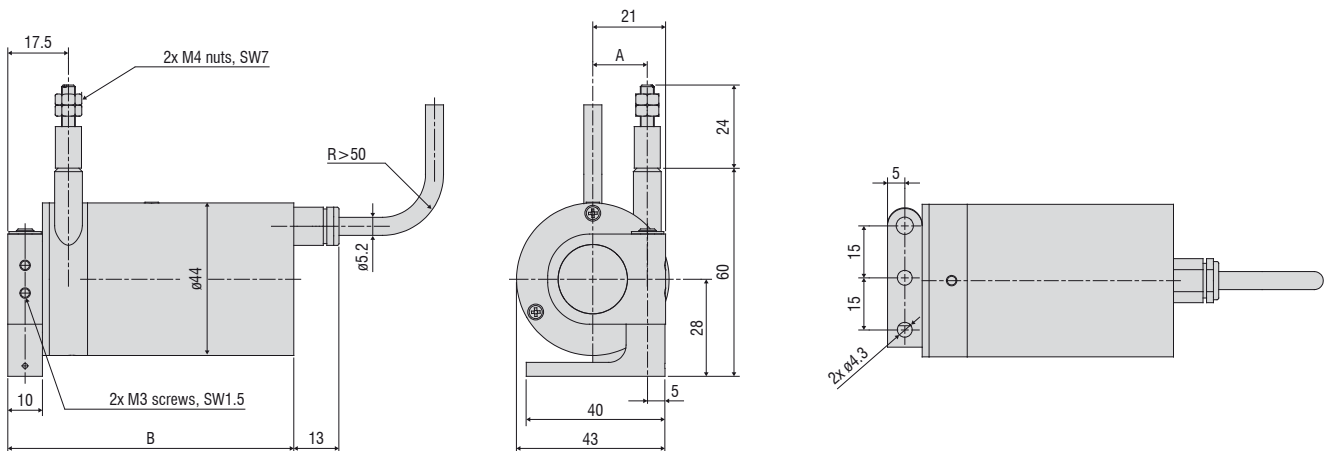

Measuring range (mm)	A (mm)	B (mm)
100 / 300 / 500 / 1000-MP	15.7	82.5
100 / 300 / 500 / 1000-MPW	15.7	86.5

Dimensions in mm, not to scale.

Model	WDS-100-MP(W)	WDS-300-MP(W)	WDS-500-MP(W)	WDS-1000-MP(W)
Measuring range	100 mm	300 mm	500 mm	1000 mm
Analog output	Potentiometer			
Resolution	0.15 mm	0.2 mm	towards infinity	
Linearity	Hybrid potentiometer P10 $\leq \pm 0.1$ % FSO	-	-	$\leq \pm 0.5$ mm
	Wire potentiometer P25 $\leq \pm 0.25$ % FSO	-	$\leq \pm 0.75$ mm	-
	Wire potentiometer P50 $\leq \pm 0.5$ % FSO	$\leq \pm 0.5$ mm	-	-
Sensor element	Wire potentiometer		Hybrid potentiometer	
Wire extension force (max.)	approx. 8.5 N	approx. 8.5 N	approx. 8.5 N	approx. 8 N
Wire retraction force (min.)	approx. 7 N	approx. 7 N	approx. 6.5 N	approx. 5 N
Wire acceleration (max.)	approx. 30 g			
Material	Housing	Aluminum		
	Measuring wire	Stainless steel (ϕ 0.45 mm)		
Wire mounting	M4 threaded bolts			
Mounting	Mounting flange rotatable in two axes 180° / 360°			
Temperature range	Storage	-20 ... +80 °C		
	Operation	-20 ... +80 °C		
Connection	integrated cable, axial, length 1 m			
Shock (DIN EN 60068-2-27)	50 g / 20 ms in 3 axes, 1000 shocks each			
Vibration (DIN EN 60068-2-6)	20 g / 20 ... 2000 Hz in 3 axes, 10 cycles each			
Protection class (DIN EN 60529)	MP series	IP65		
	MPW series	IP67		
Weight	approx. 270 g (incl. cable)			

FSO = Full Scale Output

Specifications for analog outputs from page 54 onwards.

Article designation

WDS -	100 -	MP -	C -	P
				Output type: P: potentiometer
				Connection C: integrated cable, axial, 1 m
				MP / MPW series (IP67)
				Measuring range in mm

Wire deflection pulleys for external installation

TR1-WDS	Wire deflection pulley, adjustable, for sensors with a wire diameter ≤ 0.45 mm
TR3-WDS	Wire deflection pulley, fixed, for sensors with a wire diameter ≤ 0.45 mm
TR4-WDS	Wire deflection pulley, fixed, for sensors with a wire diameter of 0.8 mm to 1 mm

TR1-WDS

Wire deflection pulley, adjustable, for sensors with a wire diameter ≤ 0.45 mm

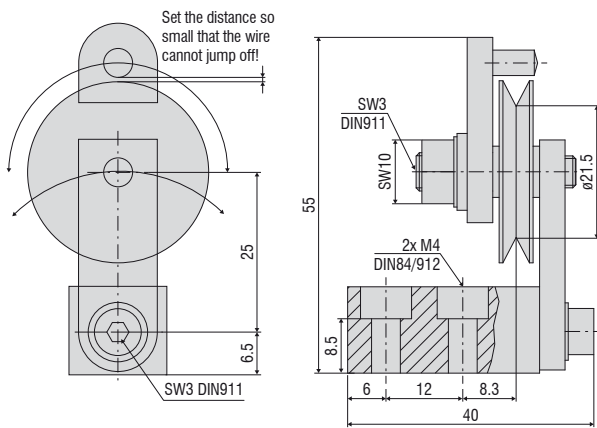

TR3-WDS

Wire deflection pulley, fixed, for sensors with a wire diameter ≤ 0.45 mm

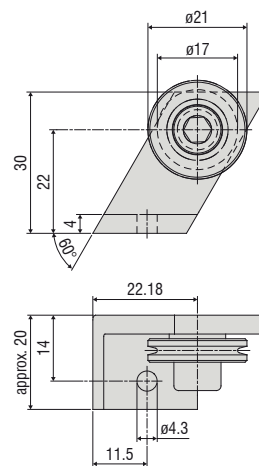

TR4-WDS

Wire deflection pulley, fixed, for sensors with a wire diameter of 0.8 mm to 1 mm

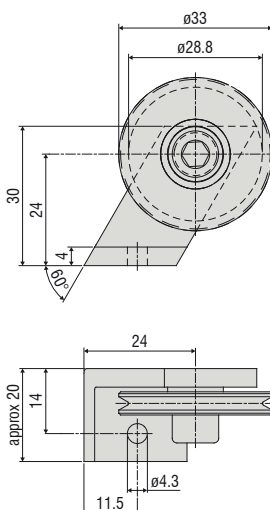

Dimensions in mm, not to scale.

Wire deflection pulley for direct installation on the sensor housing

TR5-WDS	Integrated wire deflection pulley for P115 sensors with a wire diameter of 0.45 mm
TR5-WDS(03)	Integrated double deflection pulley for P115 sensors with a wire diameter of 0.45 mm
TR5-WDS(04)	Integrated double deflection pulley, 90° angled, for P115 sensors with a wire diameter of 0.45 mm
TR6-WDS(01)	Integrated wire deflection pulley for the P115 sensors with a wire diameter of 1 mm

TR5-WDS

Integrated wire deflection pulley for P115 sensors with a wire diameter of 0.45 mm

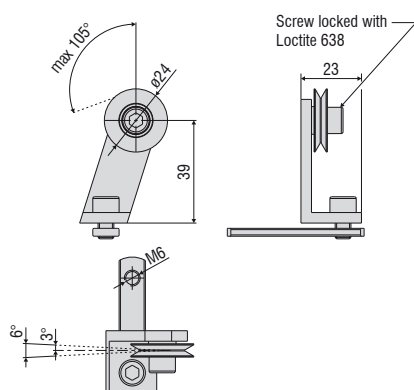

TR5-WDS(03)

Integrated double deflection pulley for P115 sensors with a wire diameter of 0.45 mm

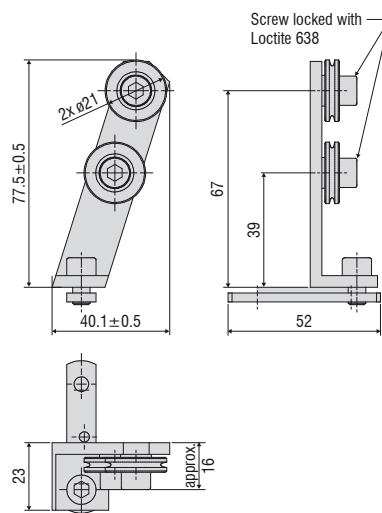

TR5-WDS(04)

Integrated double deflection pulley, 90° angled, for P115 sensors with a wire diameter of 0.45 mm

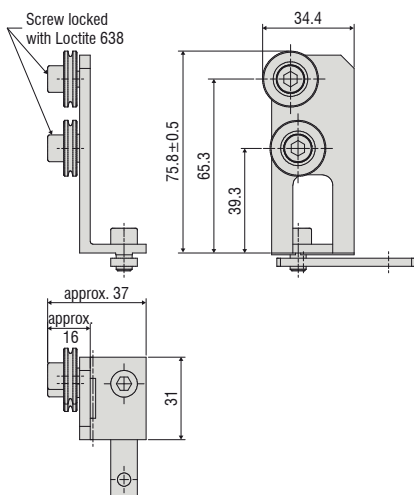

TR6-WDS(01)

Integrated wire deflection pulley for the P115 series with a wire diameter of 1 mm

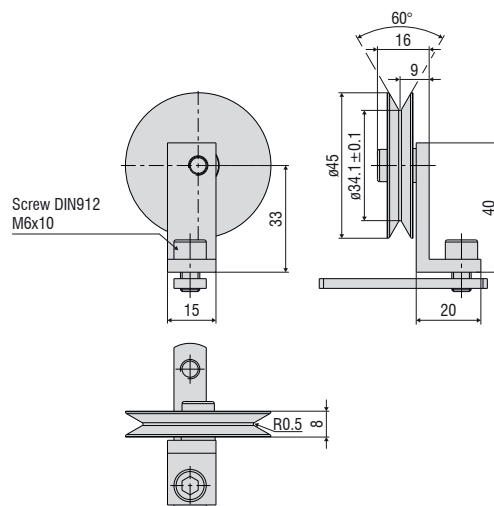

Dimensions in mm, not to scale.

Accessories

WE-xxx-M4	Wire extension with M4 wire connection, x=wire length
WE-xxx-Clip	Wire extension with eyelet, x = wire length
WE-xxx-Clip-WSS	Wire extension with clip and uncoated wire d=0.45 mm
WE-xxx-Ring-PW	Wire extension with plastic ring and para-aramid wire, 1 mm
GK1-WDS	Fork head for M4
MH1-WDS	Magnetic holder for wire attachment
MH2-WDS	Magnetic holder for sensor mounting
MT-60-WDS	Mounting clamps for WDS-P60
FC8	Mating plug for WDS straight, 8-pin
FC8/90	Mating plug, 90° angled for WDS
PC3/8-WDS	Sensor cable, 3 m long
PS2020	Power supply unit 24 V / 2.5 A; input 100-240 VAC, output 24 VDC / 2.5 A; mounting onto symmetrical standard rail 35 mm x 7.5 mm, DIN 50022)
WDS-MP60	Mounting plate for P60 models
PC2/10-WDS-A	Cable for SSI encoder, 2 m long
PC2/10-WDS-E	Cable for incremental encoder, 2 m long
PC10/10-WDS-A	Cable for SSI encoder, 10 m long
PC10/10-WDS-E	Cable for incremental encoder, 10 m long

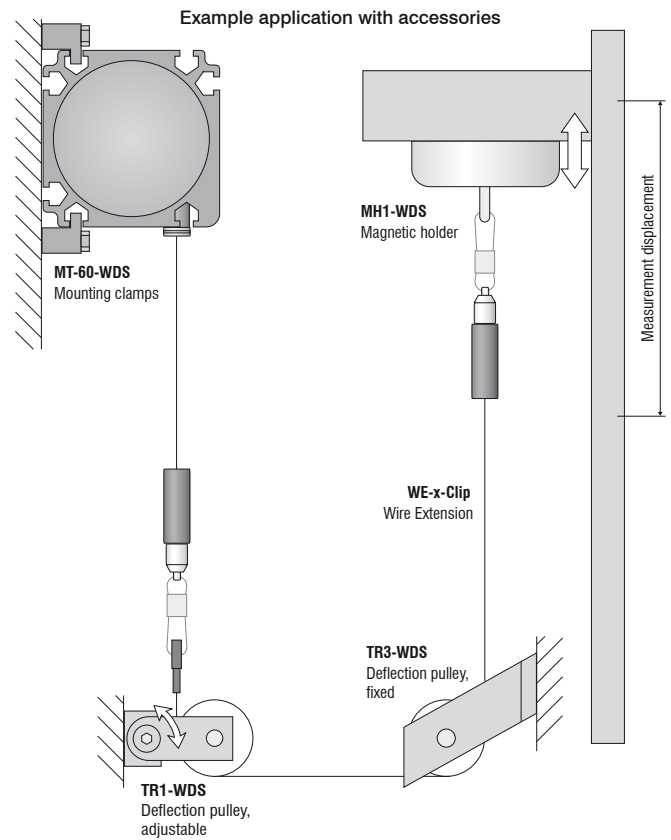

WDS-MP60
Mounting plate for P60 models

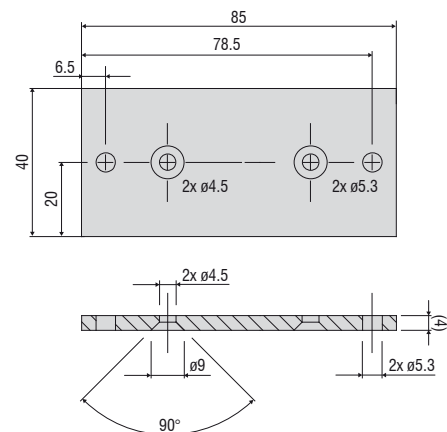
**Installation instructions:**

Wire attachment: during installation, do not allow at any time the measuring wire to freely return.

Angle of wire outlet: Make sure during installation that the wire outlet is straight (tolerance of $\pm 3^\circ$). Exceeding this tolerance leads to increased wear of the wire material and on the wire outlet.

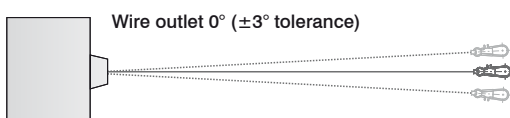

Dimensions in mm, not to scale.

WE-xxxx-M4

Wire extension with M4 wire connection, x=wire length

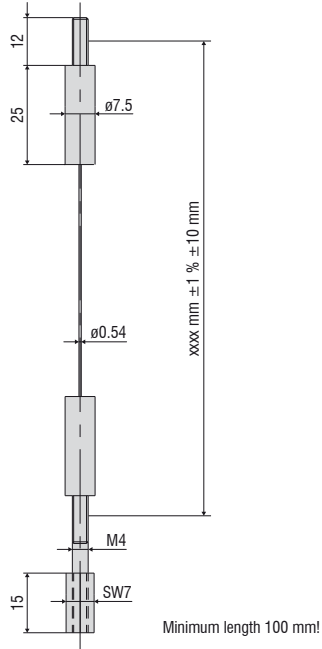

WE-xxxx-Clip

Wire extension with eyelet, x = wire length

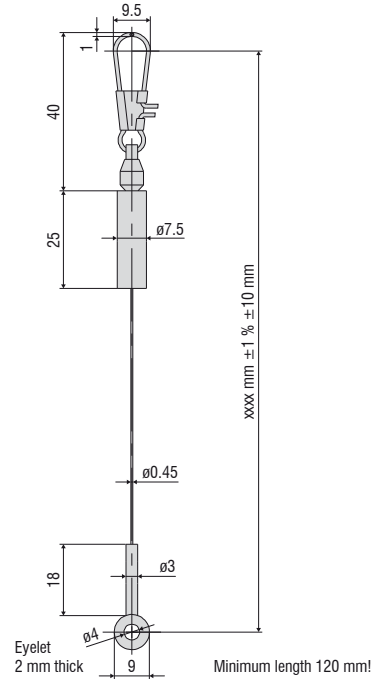

MH1-WDS

Magnetic holder for wire attachment

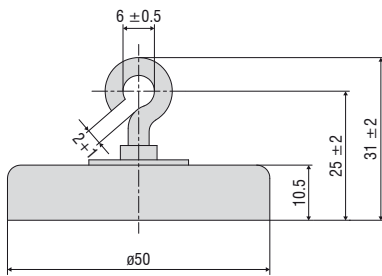

MH2-WDS

Magnetic holder for sensor mounting

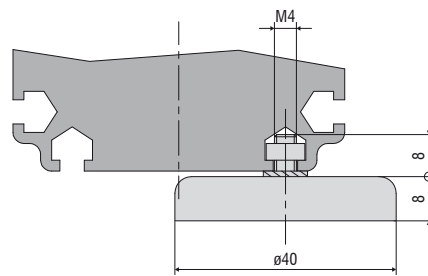

GK1-WDS

Fork head for M4

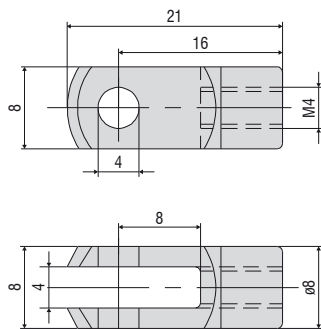

MT-60-WDS

Mounting clamps for WDS-P60

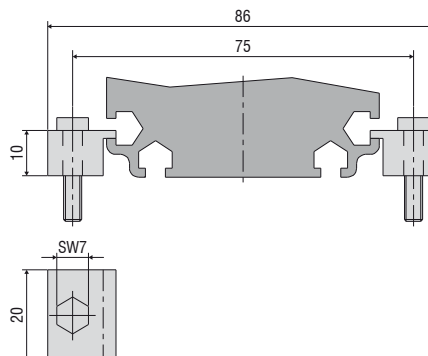

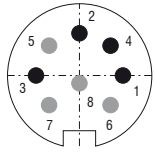
Output		Connector M16 -SA / -SR	Integrated cable -CA / -CR	Open contacts
Potentiometer output (P)		 <p>Sensor side</p> <p>1 = Input + 2 = Ground 3 = Signal</p>	<p>White = Input + Brown = Ground Green = Signal</p>	 <p>1 = Input + 2 = Signal 3 = Ground</p>
Input voltage	max. 32 VDC with 1 kOhm / max. 1 W			
Resistance	1 kOhm $\pm 10\%$ (resistance divider)			
Temperature coefficient	$\pm 0.0025\%$ FSO/ $^{\circ}$ C			
Voltage output (U)		 <p>Sensor side</p> <p>1 = Power supply 2 = Ground 3 = Signal 4 = Ground</p>	<p>White = Supply Brown = Ground Green = Signal Yellow = Ground</p>	
Supply voltage	14 ... 27 VDC (non-stabilized)			
Current consumption	max. 30 mA			
Output voltage	0 ... 10 VDC Option 0 ... 5 / ± 5 V			
Load resistance	> 5 kOhm			
Output noise	0.5 mV _{eff}			
Temperature coefficient	$\pm 0.005\%$ FSO/ $^{\circ}$ C			
Electromagnetic compatibility (EMC)	EN 61000-6-4 EN 61000-6-2			
Adjustment range (if supported by the model)				
Zero	$\pm 20\%$ FSO			
Sensitivity	$\pm 20\%$			
Current output (I)		 <p>Sensor side</p> <p>1 = Power supply 2 = Ground</p>	<p>White = Supply Brown = Ground</p>	
Supply voltage	14 ... 27 VDC (non-stabilized)			
Current consumption	max. 35 mA			
Output current	4 ... 20 mA			
Load	< 600 Ohm			
Output noise	$< 1.6 \mu\text{A}_{\text{eff}}$			
Temperature coefficient	$\pm 0.01\%$ FSO/ $^{\circ}$ C			
Electromagnetic compatibility (EMC)	EN 61000-6-4 EN 61000-6-2			
Adjustment range (if supported by the model)				
Zero	$\pm 18\%$ FSO			
Sensitivity	$\pm 15\%$			

Sensors and Systems from Micro-Epsilon



Sensors and systems for displacement, distance and position



Sensors and measurement devices for non-contact temperature measurement



Measuring and inspection systems for metal strips, plastics and rubber



Optical micrometers and fiber optics, measuring and test amplifiers



Color recognition sensors, LED analyzers and inline color spectrometers



3D measurement technology for dimensional testing and surface inspection